

GS FLX Titanium General Library Preparation Method Manual

April 2009

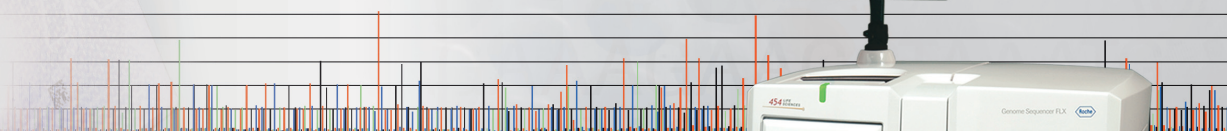
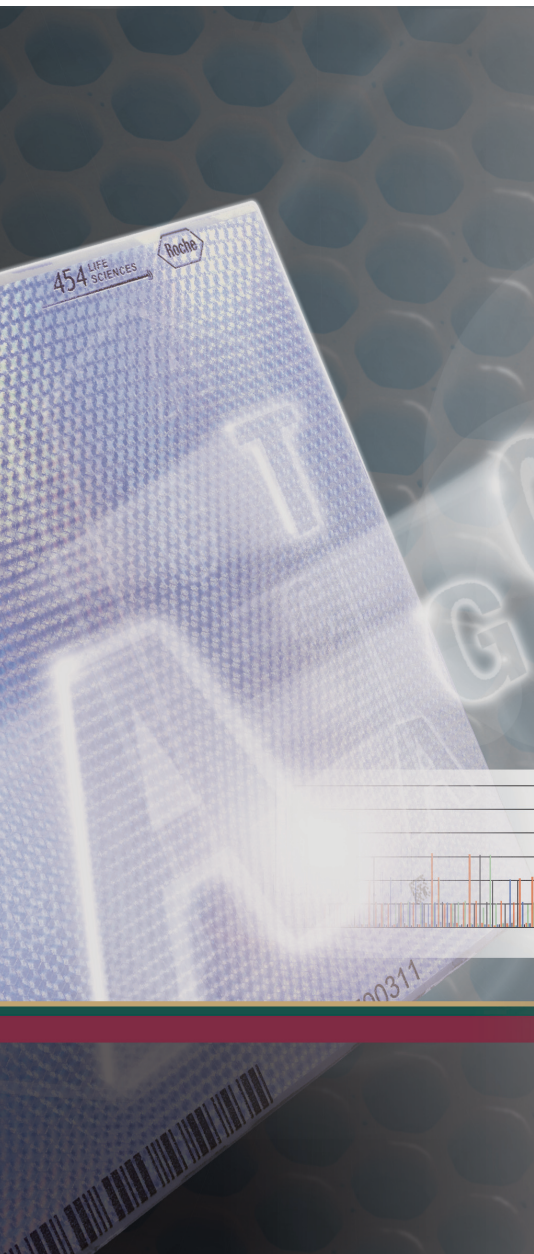
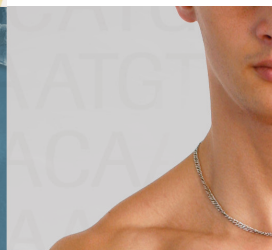
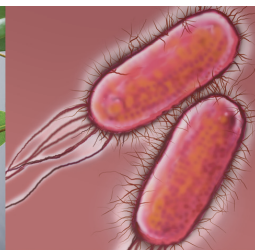

Preface

Preface	5
About this Manual.....	5
Safety.....	6
Assumptions	7
Sample ready.....	7
Trained personnel	7
Color Code	7

Introduction to the General Library Preparation Method

1. Introduction to the General Library Preparation Method	8
--	---

Before You Begin

2. Before You Begin	15
2.1 Physical Installations	15
2.2 What You Should Have Before Starting	16
2.2.1 DNA Sample.....	16
2.2.2 GS FLX Titanium General Library Preparation Kit.....	16
2.2.3 Materials Required but Not Provided.....	17
2.3 AMPure Bead Calibration Requirement	17

Procedure

3. Procedure	18
3.1 DNA Fragmentation (Nebulization).....	19
3.1.1 Nebulizer Assembly and DNA Sample Dilution.....	19
3.1.2 DNA Nebulization and Collection/Purification of the Fragmented DNA.....	20
3.2 DNA Fragment Size Selection.....	21
3.2.1 Option 1: the Gel Cut Method.....	21
3.2.2 Option 2: the Double SPRI Method	22
3.3 DNA Sample Quality Assessment (Nebulized or LMW DNA sample)	23
3.4 Fragment End Polishing	23
3.5 Adaptor Ligation	24
3.6 Small Fragment Removal.....	24
3.7 Library Immobilization.....	25
3.8 Fill-In Reaction.....	26
3.9 Single-Stranded DNA Library Isolation.....	26
3.10 DNA Library Quality Assessment and Quantitation.....	27
3.10.1 Library Quality Assessment and Physical Quantitation.....	27
3.10.2 Library Primary Dilution and Storage	27
3.10.3 Determination of the Amount of Library to Use in emPCR Amplification	28
3.10.3.1 Option 1: Emulsion Titration Assay	28
3.10.3.2 Option 2: Full Sequencing Titration Assay	30
3.10.4 Preparation of Working Aliquots.....	31

Where to Go from Here

4. Where to Go from Here 32

Appendix

5. Appendix 33

5.1 Table of Materials Required but Not Provided..... 33

5.2 Reagents Prepared by the User 36

5.2.1 Melt Solution 36

5.3 AMPure Bead Calibration Procedure..... 37

5.3.1 Materials Needed: 38

5.3.2 Procedure..... 39

5.3.3 Analysis 40

5.4 Gel-Cut Example 43

5.5 Example of an Agilent 2100 Trace of a Nebulized and Size-Selected DNA Sample..... 44

5.6 Example of an Agilent 2100 Trace of a Final Library 45

5.7 Example BioAnalyzer Traces for LMW DNA Samples and Prepared Libraries..... 46

5.8 Additional Information 48

5.8.1 Revision History 48

5.8.2 Related Publications 48

5.8.3 Intended Use 50

5.8.4 Notice to Purchaser 50

5.8.5 Trademarks 50

5.8.6 Assistance 50

Preface

About this Manual

This manual describes the method to process a DNA sample into a library of single-stranded DNA fragments for sequencing in the Genome Sequencer System. The method is typically used to produce Shotgun DNA libraries from genomic DNA samples or other complex libraries, suitable for the Genome Sequencer FLX Titanium platform. This method uses the GS FLX Titanium General DNA Library Preparation Kit and results in template fragments that are flanked with amplification and sequencing primer sequences; the method also shows how to quantitate the library for use in the GS FLX Titanium emulsion PCR (emPCR) amplification method.

Variant procedures describe how to prepare libraries from complex DNA samples of either high or low molecular weight. [Information and procedural steps specific to low molecular weight \(LMW\) DNA samples are marked in blue.](#)

The Genome Sequencer System for DNA Sequencing was developed by 454 Life Sciences, a Roche company.



Important Note: With the April 2009 release, Roche adds Paired End capabilities to the existing non-MID “General” (e.g. Shotgun) sequencing applications supported by the GS FLX Titanium series chemistry for the Genome Sequencer FLX System. For Amplicon sequencing, or for the preparation and sequencing of MID libraries of any type, users must continue to use the GS FLX standard series kits and procedures (last updated in December 2007).

Note, however, that samples prepared using kits and procedures from the GS FLX Titanium series are still sequenced on the same Genome Sequencer FLX Instrument. Also, the Genome Sequencer FLX Software version 2.0.xx, associated with the October 2008 and April 2009 releases, can process datasets generated with any of the Genome Sequencer’s chemistries (GS 20, GS FLX standard, and GS FLX Titanium). Indeed, the software version 2.0 can co-process reads produced on any combination of Genome Sequencer System chemistries (and even “Sanger reads”) within a given analysis, such as in an Assembly, a Mapping, or an Amplicon Variant Analysis Project.

The Genome Sequencer FLX Titanium series manuals are easily identified by their new cover graphics and distinctive tri-color stripes (reflecting the GS FLX Titanium kits packaging). All the methods, protocols and applications supported on the GS FLX standard chemistry will be enabled on the GS FLX Titanium chemistry in the near future.



Incompatible chemistries: The two different chemistries of the Genome Sequencer System (GS FLX standard and GS FLX Titanium) are completely incompatible with each other. For example, standard libraries cannot be amplified using GS FLX Titanium series emPCR kits, and libraries prepared/amplified with GS FLX Titanium series kits cannot be sequenced on the standard PicoTiterPlate devices, or vice-versa. **It is crucially important that kits and procedures belonging to a single chemistry platform be used throughout the preparation, amplification and sequencing of a DNA sample.**





The kits and procedures described in this document must be used only to prepare non-MID General libraries, which must then be amplified using one of the two available GS FLX Titanium emPCR kits according to the *GS FLX Titanium emPCR Method Manual*.



In this manual, the phrase “Genome Sequencer System” refers to the whole system for DNA sequencing developed by 454 Life Sciences Corp., including the Genome Sequencer Instrument, all the kits for the preparation, amplification and sequencing of a DNA sample, the methods to use the kits as described in the Manuals and Guides, and the software provided to process and analyze the data from sequencing Runs. Likewise, “Genome Sequencer FLX System” refers to a Genome Sequencer System based on the Genome Sequencer FLX Instrument (as opposed to the Genome Sequencer 20 Instrument, which is now retired). Two versions of the Genome Sequencer FLX System have been released: the GS FLX standard series, last updated in December 2007, and the GS FLX Titanium series. 454 Life Sciences Corporation is a Roche company.

Safety

Make sure to follow the precautionary statements presented in this manual. Such statements and other items of special interest are highlighted with the following icons:

Symbol	Heading	Description
	Warning	Indicates the possibility of severe or fatal injury to the user or other persons, or damage to a system component, if the precautions or instructions are not observed.
	Caution	Highlights information that is critical for optimal performance of the system. May also indicate that loss of data or the generation of invalid data could occur if the precautions or instructions are not observed.
	Information Note	Identifies items of general interest and additional information about the topic or procedure being described.
		Table continued on next page.
		End of table.

Assumptions

Sample ready

This manual describes the conversion of a DNA sample into a "General" DNA (e.g., Shotgun) library for sequencing with the Genome Sequencer System. Therefore, the procedures described assume that the user already has on hand a suitable DNA sample that meets the requirements listed in section 2.2.1, below.

Trained personnel



Trained personnel: This manual assumes that the person carrying out the procedures described herein is trained in proper and safe laboratory techniques, and in the correct handling of all kit components. Throughout the documentation of the Genome Sequencer System, the words "user" and "you" refer to properly trained individuals. If you have any questions, please contact your Roche Representative for information about user training.

Color Code

The procedure described in this manual can be carried out on DNA samples that are initially of High Molecular Weight, such as genomic DNA; or that are intrinsically of Low Molecular Weight (LMW), such as DNA libraries prepared from microRNA. Specific instructions for the processing of LMW DNA samples are shown in a color-coded font, based on the table below.

The procedure for this DNA sample	... is typed in this color
High Molecular Weight (HMW)	Regular black type
Low Molecular Weight (LMW)	Blue type if different from HMW

Mostly, blue type will indicate that LMW DNA samples do not need to be nebulized (section 3.1) or size-selected (section 3.2), and that the specifications and amount of input DNA are different from the requirements for HMW DNA samples (section 3.4). Also, the small fragment removal step (section 3.6) is omitted when preparing a LMW DNA library.

1. Introduction to the General Library Preparation Method

The Genome Sequencer System provides a unique technology for sequencing DNA samples in an efficient, massively parallel, and cost-effective manner. The procedures described in this manual are used to create a library of fragments from a DNA sample (*e.g.*, genomic DNA from an organism of interest, BACs, YACs, cosmids, *etc.*) to be sequenced by shotgun sequencing. Such a library consists of a random set of single-stranded DNA fragments representing the whole span of the sample sequence. Each fragment is flanked by suitable amplification and sequencing DNA adaptors, and the library must be purified and quantitated before further processing. This manual describes the method to prepare a "General" library, using the GS FLX Titanium General Library Preparation Kit. In this context, a General library means a library other than a Paired End or an Amplicon library. This technology is suitable for genomes of any size, and the library preparation process can be performed in a few hours by a single individual in a suitably equipped laboratory.

A variation on the standard procedure describes how to prepare General libraries from Low Molecular Weight DNA (LMW DNA) samples. For the purpose of this special procedure, LMW DNA is defined as a sample comprised of fragments in the 70–800 bp range. Examples include short sequence tags, PCR products, cDNA derived from microRNAs, *etc.*



Throughout this manual, information and procedural steps specific to the processing of LMW DNA samples are written in blue text.

Each GS FLX Titanium General Library Preparation Kit contains enough reagents to prepare ten separate libraries, and each preparation generates sufficient DNA for thousands of amplification and sequencing rounds.

The General library preparation method comprises ten main steps, as shown in Figure 1–1 and briefly described below. Sections 3.1 through 3.10 of this manual describe the corresponding procedures in detail.

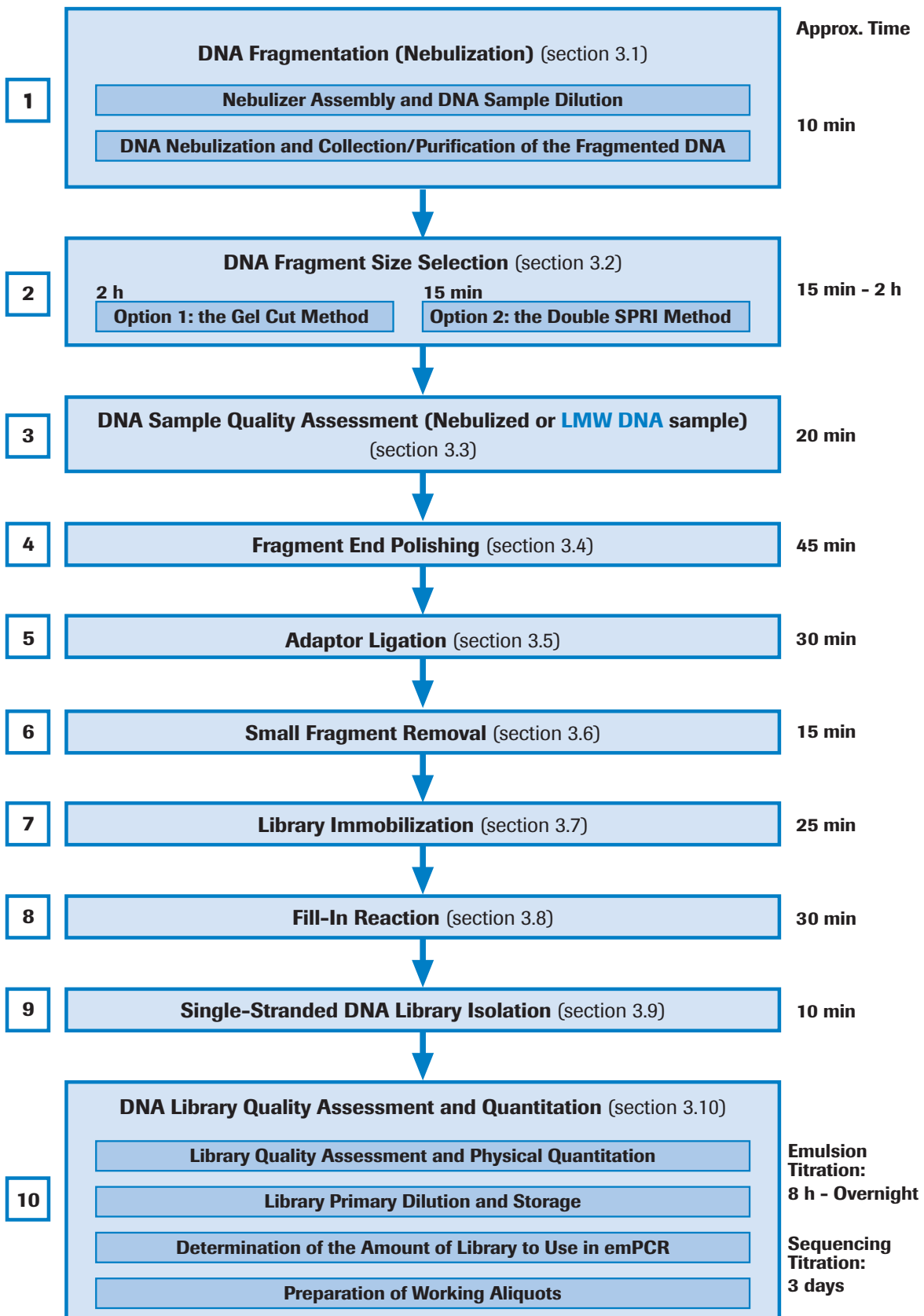

Figure 1–1: The ten step workflow of the General library preparation procedure for the Genome Sequencer FLX Titanium System



- 1 DNA Fragmentation (Nebulization):** The first step of the preparation is the fragmentation of the high molecular weight DNA sample (genomic DNA, BACs, YACs, cosmids, *etc.*) into smaller molecular species appropriate for sequencing using the GS FLX Titanium chemistry. This is done by nebulization, which shears double-stranded DNA into fragments ranging from about 400 to 1000 base pairs. This population of smaller-sized DNA species, generated from a single DNA sample, is referred to as a “library”.

An alternative procedure is provided for low molecular weight DNA. Some examples of LMW DNA are short sequence tags, some PCR products, and cDNA derived from microRNAs. The LMW DNA procedure skips the nebulization and fragment size selection steps of the procedure.

► For the complete procedure of DNA fragmentation, see section 3.1 of this manual.



- 2 DNA Fragment Size Selection:** Nebulization yields fragments with a fairly broad distribution of lengths, but the system works best in the 500 to 800 bp length range: shorter fragments would not take advantage of the extra-long read length capabilities of the GS FLX Titanium chemistry; while longer fragments would not amplify well in emPCR amplification and may result in reads with low signal (and actually *shorter* average read length due to trimming of the lower quality distal end of those reads). This manual describes two options for fragment size selection:

- The Gel Cut option offers very good control of both the upper and lower margins of fragment sizes, and usually generates the best sequencing results.
- The Double SPRI option is a fast and convenient method that is especially appropriate when preparing multiple samples in parallel. However, it removes only short fragments, and the cut-off is not as sharp or well defined as with the Gel Cut option.

► For the complete procedure of DNA fragment size selection, see section 3.2 of this manual.

- 3 DNA Sample Quality Assessment (Nebulized or LMW DNA sample):**

The fragment length distribution of the library is assessed to make sure that the input material is adequate. For LMW DNA samples, which are not nebulized or size-selected, this is the entry point into the procedure.

► For the complete procedure of DNA quality assessment, see section 3.3 of this manual.



- 4 Fragment End Polishing:** Nebulization of DNA yields some fragments with frayed ends. These ends are made blunt and ready for ligation to adaptors by the action of T4 DNA polymerase and T4 polynucleotide kinase (T4 PNK). The 5'→3' polymerase activity of T4 DNA polymerase fills in 3'-recessed ends (5'-overhangs) of DNA, while its single-stranded 3'→5' exonuclease activity removes 3'-overhang ends. The kinase activity of T4 PNK adds phosphate groups to the polished 5'-hydroxyl termini.

► For the complete procedure of fragment end polishing, see section 3.4 of this manual.



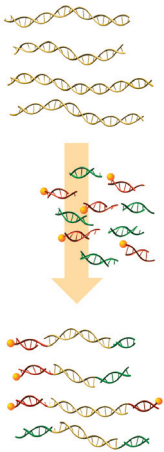

- 5 Adaptor Ligation:** Following fragmentation and polishing of the DNA library, primer sequences termed “Adaptors” are ligated to the ends of each sample DNA fragment. These Adaptors are a pair of double-stranded oligonucleotides (Adaptors “A” and “B”) that provide priming regions to support both amplification and nucleotide sequencing. They also provide a unique 4-base nonpalindromic sequencing key used by the system’s software for base calling and to recognize legitimate library reads. Adaptor B also contains a biotin tag on its 5’-strand.

All Adaptors are designed to allow directional ligation to the polished double-stranded DNA (dsDNA) library fragments: each Adaptor contains a 5’-overhang at the amplification and sequencing priming end, and a blunt-ended 3’ key region. Thus, only the 3’ key region can ligate to the blunt-ended dsDNA fragments. Also, the biotin tag on Adaptor B allows the immobilization of the dsDNA library fragments and the subsequent isolation of the library of ssDNA sequencing templates (see “*Library immobilization*”, step 7 below).

Adaptors are combined with the DNA fragments in a ligation reaction that contains a large molar excess of adaptors (~ 15:1 adaptor:fragment ratio), both to maximize utilization of the dsDNA library fragments and to minimize the formation of fragment concatemers. The adaptors are non-phosphorylated to minimize the formation of adaptor dimers; consequently, the ligation products must be repaired with a fill-in reaction (see “*Fill-in reaction*”, step 8 below).

► For the complete procedure of Adaptor ligation, see section 3.5 of this manual.

- 6 Small Fragment Removal:** During adaptor ligation there are instances of adaptors ligating to each other thus forming adaptor dimers. This small fragment removal step removes small molecular species and artifacts such as adaptor dimers from the sample DNA.

► For the complete procedure of small fragment removal, see section 3.6 of this manual.



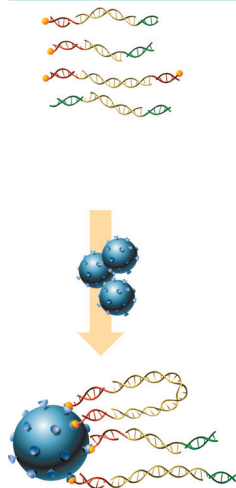

7 Library Immobilization: The ligation mixture is immobilized onto magnetic streptavidin-coated beads, via the biotin moiety of Adaptor B. The ligation reaction produces a mixture of molecular species including: sample DNA fragments with ligated adaptors on either or both ends, unligated or self-ligated (circularized) sample DNA fragments, unbound single Adaptors, and Adaptor dimers. Of these, the “adapted” sample DNA fragments will have adaptors bound in the following possible configurations:

Configuration	Fate in Library Preparation
Adaptor A - DNA Fragment - Adaptor A	Fragments flanked by two Adaptor A (or non-ligated / circularized species) will not bind to the streptavidin beads, and will be removed during the wash procedure.
Adaptor A - DNA Fragment -	Fragments flanked by a single Adaptor A will also fail to bind to the streptavidin beads, and will be removed during the wash procedure.
Adaptor A - DNA Fragment - Adaptor B and Adaptor B - DNA Fragment - Adaptor A	Fragments flanked by one Adaptor A and one Adaptor B will ultimately become the single-stranded template DNA library: the strand containing the biotinylated Adaptor B allows it to be captured by the streptavidin-coated beads, while the other strand will be released during the ssDNA library isolation step (see “ <i>Single-Stranded DNA Library Isolation</i> ”, step 9 below).
Adaptor B - DNA Fragment - Adaptor B	Fragments flanked by two Adaptor B species will have both strands bound to the beads. These will not contribute to the single-stranded DNA library because neither strand will be released during the ssDNA library isolation step (see “ <i>Single-Stranded DNA Library Isolation</i> ”, step 9 below).
Adaptor B - DNA Fragment -	Fragments flanked by a single Adaptor B will bind to the streptavidin beads, and their non-anchored strands will be released during the ssDNA library isolation step, but they will not amplify during emPCR amplification because they cannot bind the Adaptor A Amplification Primer (see the <i>GS FLX Titanium emPCR Method Manual</i> for details on the emPCR amplification procedure).

Table 1-1: Fates of the five possible Adaptor configurations for “adapted” sample DNA fragments

The most common contaminant in this procedure is Adaptor dimers, but normally such contaminants are removed during later steps.

► For the complete procedure of library immobilization, see section 3.7 of this manual.



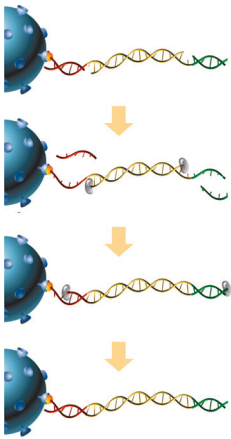

8 Fill-In Reaction: Because the DNA oligonucleotides used for the Adaptors are not phosphorylated, gaps will be present at their 3'-junctions with the sample DNA fragments. These two gaps or nicks are repaired using a strand-displacing DNA polymerase, which recognizes the nicks, displaces the nicked strands (starting from the free 3'-end of each library fragment), and fills in the single-stranded gap, producing full-length dsDNA.

► For the complete procedure of the fill-in reaction, see section 3.8 of this manual.

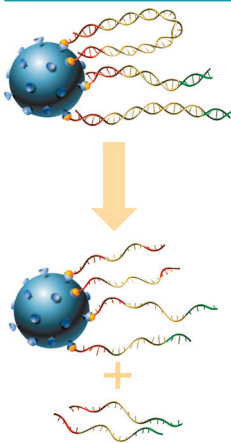

9 Single-Stranded DNA Library Isolation: The next step isolates the single-stranded moieties by melting off the non-biotinylated strand of each dsDNA fragment. As explained above, the adapted dsDNA fragments are immobilized via the biotin tag of Adaptor B. Therefore, fragments *without* an Adaptor B have already been washed away, and fragments with Adaptor B at *both* ends will not release either strand. The procedure is thus designed to generate a library comprising only ssDNA molecules flanked with Adaptor A at the 5'-end and Adaptor B at the 3'-end.

► For the complete procedure of ssDNA library isolation, see section 3.9 of this manual.



10 DNA Library Quality Assessment and Quantitation: The quality of the DNA library preparation is assessed with an Agilent 2100 BioAnalyzer, for:

- ▶ fragment size range and average size, and
- ▶ the presence and prevalence of contaminating Adaptor dimers.

Then, the library is quantitated using the RiboGreen method, and the yield is calculated.

The emPCR amplification process achieves clonal amplification by immobilizing the ssDNA library fragments onto Capture Beads and then physically separating those beads into an emulsion of water-in-oil droplets for the amplification reaction. (For more information on the emPCR amplification process, see the *GS FLX Titanium emPCR Method Manual*.) The amount of the library that will deliver exactly one molecule of ssDNA per Capture Bead can be calculated from the yield assessment. Due to certain inefficiencies inherent to the amplification reaction and some library molecules not containing an Adaptor A, however, not every DNA molecule present will be amplified. Consequently, an optimal emPCR amplification reaction requires the delivery of the DNA amount that will result in a single molecule of ssDNA *being amplified* per bead.

This manual offers a two options to determine the optimal amount of DNA library to be used for emPCR amplification. Users should select the option which best supports their particular circumstances and experimental requirements.

▶ **Option 1: Emulsion titration.** There exists a strong correlation between the quality of the sequencing results one normally obtains with a given DNA library, and the percentage of bead enrichment obtained during the emPCR amplification of the library. Option 1 uses the % bead enrichment of a set of quick emPCR amplification reactions carried out with different amounts of DNA as a proxy to determine the amount that will produce the best sequencing results. Option 1 is recommended for experienced users.

▶ **Option 2 : Sequencing titration.** Option 2 consists of the same type of emulsion titration as in Option 1, followed by a sequencing Run of the amplified tests. Option 2 provides a full functional determination of the amount of DNA input in emPCR amplification that does, in fact, provide the best sequencing results. This is a more extensive and complete process, and is recommended for new users who are unfamiliar with the process, and for users working with either very rare sample types (such as ancient DNA) or extremely small sample sizes. It is also an appropriate choice for users who plan to perform a large number of sequencing Runs with a given library, as these may most benefit from such optimization.

▶ *For the complete procedure of DNA library quality assessment and quantitation, see section 3.10 of this manual.*



▶ The Genome Sequencer FLX Titanium System can produce yields in the range of about 500 million high-quality, filter-passed bases per sequencing Run. This assumes that the majority of sequenced DNA fragments are at least 400 nucleotides in length (so they can achieve maximum read length), and that the Run produced approximately 1.25 million reads (on a 70 × 75 mm PicoTiterPlate device, with a 2-large regions gasket). **However, in libraries prepared from low molecular weight DNA samples, many of the fragments may be substantially shorter than 400 nucleotides. When that is the case, or when a smaller Pico-TiterPlate device or a Bead Loading Gasket with smaller regions are used, the expected output per Run will be substantially lower.**

▶ General DNA libraries prepared with the Adaptors provided in the GS FLX Titanium Library Preparation Kit must be amplified using the GS FLX Titanium LV emPCR Kit (Lib-L) or the GS FLX Titanium SV emPCR Kit (Lib-L).

2. Before You Begin

This section describes the main prerequisites for the preparation of a General library for sequencing with the GS FLX Titanium chemistry, as detailed in section 3 of this manual. Before starting such a preparation, make sure that all the requirements listed in this section are met. The section is divided into the following:

- ▶ Section 2.1: Physical Installations
- ▶ Section 2.2: What You Should Have Before Starting

2.1 Physical Installations

Always take precautions to prevent contamination of sample DNA with PCR amplicons or other extraneous DNA. To minimize the risk of contamination, ensure the following:

- ▶ Perform the DNA library preparation procedure in a laboratory that is physically separated from areas where PCR is performed.
- ▶ Do not bring amplified DNA into the laboratory where DNA library preparation is performed.
- ▶ Do not enter the Library Preparation laboratory if you have been handling reactions in the PCR laboratory.
- ▶ It is **crucially important** that the laboratory be equipped with an externally ventilated hood, and that the nebulization of the DNA sample be performed in this hood (**unless you will be preparing ONLY libraries from low molecular weight DNA, which do not need to be nebulized**). This will minimize the risk of aerosolized DNA contaminating your Library Preparation lab.

For a full description of the Library Preparation laboratory requirements, see the *Genome Sequencer System Site Preparation Guide*.

2.2 What You Should Have Before Starting

2.2.1 DNA Sample

The quality and quantity of the DNA sample are critical to the success of this procedure. Any contamination in the starting material will be directly reflected in the output library.

The procedure requires 3 - 5 µg of input DNA when using the Double SPRI size selection method, and 5 - 10 µg when using the Gel Cut method, or 1 µg for LMW DNA samples. Ideally, the DNA should be checked to ensure it is derived from the target organism and contains no other contaminating DNA. At a minimum, the DNA sample should meet the following criteria:

- ▶ DNA must be double-stranded
- ▶ DNA should not be the result of whole genome amplification (or other similar process which may compromise representativity)
- ▶ DNA should not be degraded, *i.e.* starting DNA material should be in pieces > 1.5 kb (70 - 800 bp for LMW DNA)
- ▶ DNA should contain no particulate matter
- ▶ DNA should have an OD_{260/280} ratio of approximately 1.8
- ▶ DNA sample should have a minimal concentration of 50 ng/µl, in TE



▶ Because DNA quantitation using OD₂₆₀ is variable and dependent upon DNA purity, the input DNA concentration should be verified by fluorometry (*e.g.*, PicoGreen-based fluorometry) or densitometry (*e.g.*, after gel electrophoresis on a 1 - 2% agarose gel using a DNA Mass Ladder).

▶ The process (**even when using the LMW DNA procedure**) may work poorly for molecular species smaller than 70 bp because shorter DNA may be lost during the end polishing column purification step. Also, during data processing, reads shorter than approximately 50 nucleotides will be discarded by the software as being too short.

▶ Fragments longer than 800 bp do not amplify well in the emPCR amplification process, so this is the upper size limit for non-nebulized samples.

2.2.2 GS FLX Titanium General Library Preparation Kit

The GS FLX Titanium Library Preparation Kit comes in 10× format, *i.e.*, it contains enough reagents and other components for 10 individual library preparations. It is shipped in four separate containers, to accommodate the shipping and storage temperature requirements of each component. Table 2-1 lists the contents of the four containers of the GS FLX Titanium Library Preparation Kit. Note that the content of the Buffers box must be thawed at +2 to +8°C prior to use, which takes about 24 hours.



▶ To avoid having to repeat this 24 hour thaw period, the Buffers box can be stored at +2 to +8°C temporarily if the kit is to be re-used for another library preparation within a few days. Otherwise, these reagents should be refrozen after use, to minimize the risk of microbial growth.

Box Name	Temperature		Kit component	Quantity
	Ship	Store		
Nebulizers ^a	Room Temp	Room Temp	Aeromist Nebulizer and Tubing	10 ea
			Nebulizer Condensor Tubes	10 ea
			Nebulizer Snap Caps ^b	10 ea
Library Immobilization Beads	Room Temp	+2°C to +8°C	Library Immobilization Beads	500 µl
Buffers	Dry ice	-15°C to -25°C	TE Buffer	10 ml
			Nebulization Buffer	5 ml
			2× Library Binding Buffer	2.25 ml
			Library Wash Buffer	4 ml
Titanium General Library Reagents	Dry ice	-15°C to -25°C	BSA	50 µl
			dNTP Mix	40 µl
			10× Polishing Buffer	50 µl
			ATP	50 µl
			T4 DNA Polymerase	50 µl
			T4 PNK	50 µl
			2× Ligase Buffer	200 µl
			Ligase	40 µl
			10× Fill-in Polymerase Buffer	50 µl
			Fill-in Polymerase	30 µl
Adaptors	60 µl			
Water, Molecular Biology Grade	1000 µl			

Table 2–1: Composition of the GS FLX Titanium General Library Preparation Kit (10×)

Room Temp: Room Temperature (+15 to +25°C). ^a **The Nebulizers are not used with Low Molecular Weight DNA samples.** ^b The “Nebulizers” subkit is common between this kit and the GS DNA Library Preparation Kit, used to prepare Shotgun (sstDNA) libraries under the GS FLX standard chemistry. The Nebulizer Snap Caps are used only when preparing libraries under the GS FLX standard chemistry, and not under the GS FLX Titanium chemistry.

2.2.3 Materials Required but Not Provided

Some pieces of equipment or standard laboratory supplies, as well as some third party reagents, are not provided but are required to carry out the General library preparation procedures described in this manual. These items are listed in section 5.1. Make sure that all necessary items are available prior to beginning an experiment.

For a complete overview of related products and manuals, please visit and bookmark our home page: www.roche-applied-science.com, and our Special Interest Site on the Genome Sequencer System: www.genome-sequencing.com.

2.3 AMPure Bead Calibration Requirement





AMPure bead calibration: Due to significant variability in the size exclusion characteristics between individual lots of AMPure beads, a calibration of each lot is necessary before these beads can be used for the preparation of DNA libraries in the GS FLX Titanium Sequencing system. Make sure to always use AMPure beads from a lot calibrated per the procedure provided in section 5.3 for the preparation of your DNA libraries. This calibration procedure will determine the specific amounts of AMPure beads to use from the lot calibrated, for libraries prepared using each of the two size selection methods: Gel Cut (section 3.6) and Double SPRI (sections 3.2.2 and 3.6).

3. Procedure

The preparation of a General library for use in the Genome Sequencer System comprises ten main steps. These steps are described in this section; see also Figure 1–1 above.

- ▶ Section 3.1: DNA Fragmentation (Nebulization)
- ▶ Section 3.2: DNA Fragment Size Selection
- ▶ Section 3.3: DNA Sample Quality Assessment (Nebulized or [LMW DNA](#) sample)
- ▶ Section 3.4: Fragment End Polishing
- ▶ Section 3.5: Adaptor Ligation
- ▶ Section 3.6: Small Fragment Removal
- ▶ Section 3.7: Library Immobilization
- ▶ Section 3.8: Fill-In Reaction
- ▶ Section 3.9: Single-Stranded DNA Library Isolation
- ▶ Section 3.10: DNA Library Quality Assessment and Quantitation

General Laboratory 1

-  ▶ **DNA Contamination:** Contamination of the DNA sample with unrelated amplicons or other extraneous DNA may diminish the quality, and can lead to the failure of the subsequent sequencing Run. To reduce the risk of contamination, be careful not to introduce amplified DNA in the library preparation area, and follow proper lab technique. Always conduct the nebulization step in an externally ventilated hood, to minimize the risk of contaminating the laboratory with aerosolized DNA fragments. For more details on the facilities requirements, see section 2.1 of this manual, or the *Genome Sequencer System Site Preparation Guide*.
- ▶ **Integrity of the library material** is crucial for quality sequencing. At no point during this process should the DNA, any reaction mix, wash buffers, or any other component of the experiment reach a temperature above 37°C.
-  ▶ While multiple libraries can be prepared side-by-side, always be careful not to contaminate them with one another if doing so. The procedure below is for the preparation of *one library*.
- ▶ Variant procedures, described below, show how to prepare General libraries from complex DNA samples of either high or [low molecular weight](#).

3.1 DNA Fragmentation (Nebulization)



In those cases where the DNA sample consists of LMW DNA (*i.e.* with a size range of 70 - 800 bp), nebulization is not required. For this type of sample, skip sections 3.1 and 3.2, and proceed immediately to the quality assessment step (section 3.3).

3.1.1 Nebulizer Assembly and DNA Sample Dilution

- 1 Press the pierced rubber stopper firmly into the Nebulizer top, and insert the millipore filter unit into the stopper hole (Figure 3-1A).
- 2 Using sterile gloves, affix a Nebulizer Condensor Tube around the Aspiration tube. To ensure proper function, make sure to push the Condensor Tube all the way down around the base of the Aspiration tube, being careful not to rotate the Aspiration tube (Figure 3-1A).
 - ▶ Set the assembled Nebulizer top on the bench, with the aspiration tube pointing upwards; make sure that the inside parts do not contact any contaminated surfaces (counter top, hands).
- 3 Obtain **3 - 5 µg** of sample DNA (in TE) if you will be using the Double SPRI size selection method, or **5 - 10 µg** if using the Gel Cut method, and pipette it to the bottom (cup) of the Nebulizer.
 - ▶ See section 3.2 for some instructions to help determine the size selection method most appropriate for your experiment.
- 4 Add TE Buffer to a final volume of **100 µl**.
- 5 Add **500 µl** of Nebulization Buffer, and mix thoroughly by swirling or pipetting up and down.
- 6 Tightly screw the cup into the top of the Nebulizer, and connect one end of the Nebulizer tubing to the Nebulizer's gas inlet (Figure 3-1B).
- 7 Transfer the Nebulizer to the externally vented nebulization hood.
- 8 Connect the loose end of the Nebulizer tubing to the nitrogen tank

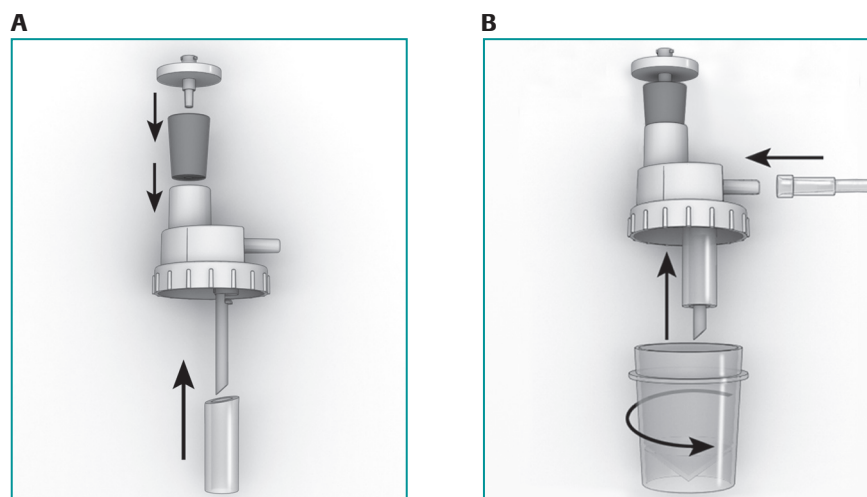



Figure 3-1: Assembling the Nebulizer

3.1.2 DNA Nebulization and Collection/Purification of the Fragmented DNA

- 1 Direct **30 psi (2.1 bar)** of nitrogen through the Nebulizer for **1 minute**, to nebulize the DNA
- 2 After nebulization, turn off the nitrogen gas flow.
- 3 Disconnect the tubing from both the Nebulizer and the nitrogen tank.
- 4 Tap the Nebulizer on a table top to collect as much of the material as possible to the bottom of the cup.
- 5 Carefully unscrew the Nebulizer top; collect and measure the volume of nebulized material with a micropipette. Total recovery should be greater than **300 µl**.
 - ▶ Do NOT collect any material that may have lodged outside the Nebulizer: this material may not have been completely fragmented and could cause problems later on.
- 6 Add **2.5 ml** of Qiagen's Buffer PBI directly into the Nebulizer cup, and swirl to collect all material droplets and mix the sample.
- 7 Purify the nebulized DNA using **two** columns from a MinElute PCR Purification Kit (Qiagen), according to the manufacturer's instructions for using spin columns and a microcentrifuge, with the following **exceptions**:
 - a. Do not use any additional PBI.
 - b. Because the sample volume is large (after addition of Qiagen's Buffer PBI), apply the sample to each column in two aliquots of ~750 µl each, spinning after each addition.
 - c. After the PE dry spin, rotate the columns 180° and spin an additional 30 seconds to ensure complete removal of the ethanol.
 - d. Elute each column with **10 µl** of Buffer EB (room temperature)
 - e. Pool the eluates of the two columns, for a total volume of **~20 µl**. Buffer EB is supplied in the Qiagen MinElute kit. To minimize the risk of contamination, Buffer EB should be aliquoted into 1 ml fractions at first opening.

3.2 DNA Fragment Size Selection

Fragment size selection can be performed in either of two ways:

- ▶ **The Gel Cut option** allows for the selection of DNA fragments from within an upper and lower range of sizes. For the Genome Sequencer FLX Titanium chemistry, the recommended size range is 500 - 800 bp.
- ▶ **The Double SPRI option** selects only DNA fragments above a certain cut-off size. For the Genome Sequencer FLX Titanium chemistry, the recommended lower size cut-off is 400 bp.

The choice between the two options should be driven by the requirements of the experiment. The Gel Cut method is often preferable, as it generates the best sequencing results. This is because it provides better control over the population of DNA fragments that will constitute the library: the user can select both the upper and lower size limits with a fair degree of precision. However, it is more time-consuming and labor-intensive than the Double SPRI method.

The Double SPRI option provides only a lower size cut-off and even so, with a margin that is usually not as sharp and not as reproducible as can be achieved with the Gel Cut method. Sequencing of these additional shorter fragments is more likely to encounter the Adaptor at the distal end of the reads, which would negatively affect read length. In addition, very long fragments produced by nebulization are not removed at all; these do not amplify as well during emPCR amplification, and the beads carrying such fragments are more likely to generate lower signals during sequencing. However, the Double SPRI method still produces excellent libraries, and because it is faster and less labor-intensive than the Gel Cut method, it may be appropriate in high-throughput environments when many libraries are prepared simultaneously. This option also requires less input DNA (about half) than the Gel Cut option.

3.2.1 Option 1: the Gel Cut Method

- 1 Prepare a **0.8%** GTG SeaKem (low melting point) agarose gel in 1× TAE Buffer (e.g. 15 cm in length; adding 0.005% EtBr to the gel for DNA visualization is convenient and appropriate).
- 2 Load the entire **20 µl** sample from section 3.1.3 (plus **2 µl** loading dye) into a single well.
 - ▶ Also load at least one well with a 100 bp DNA ladder.
- 3 Run the gel for **1.5 h at 100 V**.
- 4 Under UV illumination, cut out the library fragments between **500 and 800 bp** in size, using the ladder as a guide.

An example of the gel after excising the 500-800 bp region is provided in section 5.4.

 **Risk of DNA damage:** Do not expose the DNA sample to ultra-violet light for extended periods of time.
- 5 Purify the DNA using **one** column from a QiaQuick Gel Extraction Kit (Qiagen), according to the manufacturer's instructions for spin columns using a microcentrifuge (use a 2.0 ml tube), with the following **exceptions**:
 - a. **DO NOT USE HEAT** when "melting" the agarose gel.
 - b. Make sure to follow the isopropanol step from the manufacturer's instructions.
 - c. Follow the optional extra QG buffer spin as stated in the manufacturer's instructions.
 - d. After adding the PE to the column, incubate for **2–5 min** before spinning
 - e. After the PE dry spin, rotate the column 180° and spin an additional **1 minute** to ensure complete removal of the ethanol.
 - f. Elute the column with **24 µl** of Buffer EB (room temperature).

3.2.2 Option 2: the Double SPRI Method

-  **▶ AMPure bead purification steps:** The exact incubation volume and number of beads are critically important to the success of size exclusion steps using AMPure beads. Make sure to pipette the exact volumes of all components of such reactions, as listed in the procedure.
- ▶ AMPure bead calibration:** Due to significant variability in the size exclusion characteristics between individual lots of AMPure beads, a calibration of each lot is necessary before these beads can be used for the preparation of DNA libraries in the GS FLX Titanium Sequencing system. Make sure to always use AMPure beads from a lot calibrated per the procedure provided in section 5.3 for the preparation of your DNA libraries.

- 1** Using a pipettor, measure the volume of the pooled eluates of nebulized DNA from section 3.1.2, above.
- 2** Add Buffer EB (Qiagen) to a final volume of **100 µl**.
- 3** Add the amount of AMPure beads appropriate for the Double SPRI method, as determined per the calibration of the lot in use (section 5.3). Vortex to mix.
- 4** Incubate for **5 minutes** at room temperature.
- 5** Using a Magnetic Particle Concentrator (MPC), pellet the beads against the wall of the tube. This may take several minutes due to the high viscosity of the suspension.
 -  Leave the tube of beads in the MPC during all wash steps.
- 6** Remove the supernatant and wash the beads **twice** with **500 µl** of 70% Ethanol, incubating for 30 sec each time.
 - ▶** Small, sub-quality DNA fragments (<400 bp) do not bind well to AMPure beads under these incubation conditions, and will be washed away.
- 7** Remove all the supernatant and allow the AMPure beads to air dry completely.
 - ▶** The drying time can vary due to environmental conditions and the amount of residual fluid left in the tube.
 - ▶** The tube may be placed in a heating block set to 37°C to help speed drying; visible cracks forming in the pellet are an indication that the beads are dry.
- 8** Remove the tube from the MPC, add **24 µl** of 10 mM Tris-HCl, pH 8.0 (or Qiagen's Buffer EB), and vortex to resuspend the beads.
 - ▶** This step elutes the nebulized DNA from the AMPure beads.
- 9** Using the MPC, pellet the beads against the wall of the tube once more, and transfer the **supernatant** containing the **purified nebulized DNA** to a fresh microcentrifuge tube.

3.3 DNA Sample Quality Assessment (Nebulized or LMW DNA sample)

- 1 Run **1 µl** of the size-selected material from section 3.2 on a BioAnalyzer DNA 7500 LabChip (or, if working with LMW DNA, run the sample on a DNA 1000 LabChip) to assess the quality of the pool of fragments.
 - ▶ The recovered nebulized and size-selected material should have a mean size (top of the peak) between 500 and 800 bp, with less than 10% of the library peak below 350 bp and less than 10% above 1000 bp. See section 5.5 of this manual for a representative trace of the profile of the nebulized and size-selected material from this step.
 - ▶ LMW DNA samples should be within the 70 - 800 bp range, with either a single or multiple peaks, according to the nature of the sample. See section 5.7 for representative profiles of acceptable LMW DNA samples. Note that individual LMW DNA sample profiles may differ depending on how the sample was generated.
 - ▶ The process (even when using the LMW DNA procedure) may work poorly for molecular species smaller than 70 bp because shorter DNA may be lost during the end polishing column purification step, below. Also, during data processing, reads shorter than approximately 50 nucleotides will be discarded by the software as being too short.
 - ▶ Fragments longer than 800 bp do not amplify well in the emPCR amplification process, imposing an upper size limit for both nebulized and non-nebulized samples.

3.4 Fragment End Polishing

- 1 In a microcentrifuge tube, add the following reagents, in the order indicated:
 - ~23 µl nebulized, size-selected DNA fragments (or 1 µg of a LMW DNA sample, in TE)
 - 5 µl 10× Polishing Buffer
 - 5 µl BSA
 - 5 µl ATP
 - 2 µl dNTP Mix*
 - 5 µl T4 PNK
 - 5 µl T4 DNA polymerase
 - 50 µl final volume

* Keep the dNTP Mix handy; you will need it again for the fill-in reaction. See section 3.8 of this manual.
- 2 Mix well and incubate the polishing reaction for **15 minutes at 12°C**.
- 3 Immediately continue incubation at **25°C** for an additional **15 minutes**.
- 4 Purify the polished fragments using **one** column from a MinElute PCR Purification Kit (Qiagen), according to the manufacturer's instructions for using spin columns and a microcentrifuge, with the following **exceptions**:
 - a. Use **250 µl** of PBI.
 - b. After the PE dry spin, rotate the column 180° and spin an additional 30 seconds to ensure complete removal of the ethanol.
 - c. Elute with **10 µl** of Buffer EB (room temperature).

3.5 Adaptor Ligation



The 2 × Ligase Buffer contains ATP and DTT; it should remain capped and on ice when not frozen.

- 1 In a microcentrifuge tube, add the following reagents, in the order indicated:
~10 µl Polished DNA
20 µl 2× Ligase Buffer
5 µl Adaptors
5 µl Ligase

40 µl total

- 2 Mix well, spin briefly, and incubate the ligation reaction at **25°C for 15 minutes**.
▶ Use this 15 minute period to prepare the Library Immobilization Beads (section 3.7, steps 1 - 4).

- 3 Purify the ligation products using one column from a MinElute PCR Purification Kit (Qiagen), according to the manufacturer's instructions for using spin columns and a microcentrifuge, with the following **exceptions**:
 - a. Use **200 µl** of PBI
 - b. After the PE dry spin, rotate the column 180° and spin an additional 30 seconds to ensure complete removal of the ethanol.
 - c. Elute with **50 µl** of Buffer EB (room temperature) *or, for LMW DNA, skip directly to section 3.7, step 5, and elute the DNA directly into the tube of washed Library Immobilization Beads.*



If working with a LMW DNA sample, skip the following Small Fragment Removal step and proceed directly to section 3.7, Library Immobilization.

3.6 Small Fragment Removal



▶ **AMPure bead purification steps:** The exact incubation volume and number of beads are critically important to the success of size exclusion steps using AMPure beads. Make sure to pipette the exact volumes of all components of such reactions, as listed in the procedure.

▶ **AMPure bead calibration:** Due to significant variability in the size exclusion characteristics between individual lots of AMPure beads, a calibration of each lot is necessary before these beads can be used for the preparation of DNA libraries in the GS FLX Titanium Sequencing system. Make sure to always use AMPure beads from a lot calibrated per the procedure provided in section 5.3 for the preparation of your DNA libraries.

- 1 Using a pipettor, measure the volume of the eluate of ligated material from section 3.5, above.
- 2 Add Buffer EB (Qiagen) to a final volume of **100 µl**.
- 3 Add the amount of AMPure beads appropriate for the size selection method used, as determined per the calibration of the lot in use (section 5.3). Vortex to mix.
- 4 Incubate for **5 minutes** at room temperature.



- 5 Using a Magnetic Particle Concentrator (MPC), pellet the beads against the wall of the tube.
 - 6 Leave the tube of beads in the MPC during all wash steps.
- 6 Remove the supernatant and wash the beads **twice** with **500 µl** of 70% Ethanol, incubating for **30 seconds** each time.
 - ▶ Small, sub-quality DNA fragments (<400 bp, including primer dimers and any remaining small nebulization products) do not bind well to AMPure beads under these incubation conditions, and will be washed away.
- 7 Remove all the supernatant and allow the AMPure beads to air dry completely.
 - ▶ The drying time can vary due to environmental conditions and the amount of residual fluid left in the tube.
 - ▶ The tube may be placed in a heating block set to 37°C to help speed drying; visible cracks forming in the pellet are an indication that the beads are dry.
- 8 Remove the tube from the MPC, add **25 µl** of 10 mM Tris-HCl, pH 8.0 (or Qiagen's Buffer EB), and vortex to resuspend the beads.
 - ▶ This step elutes the Adaptor-ligated DNA from the AMPure beads.
- 9 Using the MPC, pellet the beads against the wall of the tube once more, and transfer the **supernatant** containing the **purified, Adaptor-ligated DNA** to a fresh microcentrifuge tube.

3.7 Library Immobilization

- 1 Transfer **50 µl** of Library Immobilization Beads to a fresh 1.5 ml tube.
- 2 Using the MPC, pellet the beads and remove the buffer.
- 3 Wash the Library Immobilization Beads **twice** with **100 µl** of 2× Library Binding Buffer, using the MPC.
- 4 Resuspend the beads in **25 µl** of 2× Library Binding Buffer.
- 5 Add the purified, ligated DNA (**25 µl**; from section 3.6) to the tube of washed Library Immobilization Beads. [For LMW DNA samples, you should have skipped directly to here from section 3.5, step 3.c; elute the DNA from the MinElute column with 25 µl of Buffer EB \(room temperature\) directly into the tube of washed Library Immobilization Beads.](#)
- 6 Mix well and place on a tube rotator at **ambient temperature** (22°C) for **20 minutes**.
- 7 Using the MPC, wash the immobilized Library **twice** with **100 µl** of Library Wash Buffer.
- 8 Remove all remaining Library Wash Buffer from the pelleted beads, and remove the tube from the MPC.

3.8 Fill-In Reaction

- 1 In a microcentrifuge tube, add the following reagents, in the order indicated, and mix:

40 μ l	Molecular Biology Grade water
5 μ l	10 \times Fill-in Polymerase Buffer
2 μ l	dNTP Mix
3 μ l	Fill-in Polymerase
<hr/>	
50 μ l	total
- 2 Add the **50 μ l** of fill-in reaction mix prepared in step 1 to the tube containing the library-carrying beads (from section 3.7).
- 3 Mix well and incubate at **37°C** for **20 minutes**.
- 4 Using the MPC, wash the immobilized Library **twice** with **100 μ l** of Library Wash Buffer.
- 5 Remove all remaining Library Wash Buffer from the pelleted beads, and remove the tube from the MPC.

3.9 Single-Stranded DNA Library Isolation

- 1 If necessary, prepare a stock of Melt Solution by mixing **125 μ l** of NaOH (10 N) in **9.875 ml** of Molecular Biology Grade Water, as described in section 5.2.1. This solution has a shelf life of only 7 days (at +2°C to +8°C).
- 2 In a microcentrifuge tube, prepare the neutralization solution by mixing **500 μ l** of Qiagen's PBI buffer with **10 μ l** of 3 M Sodium Acetate pH 5.2.
- 3 Separately, add **50 μ l** of Melt Solution to the washed library-carrying beads prepared in section 3.8, above.
- 4 Vortex well and using the MPC, pellet the beads away from the 50 μ l supernatant.
▶ **At this point, the supernatant contains the DNA library.**
- 5 Carefully remove and transfer the **supernatant** to the freshly-prepared neutralization solution from step 1.
- 6 Repeat steps 3-5 (second **50 μ l** Melt Solution wash of the beads), and pool the two Melt Solution washes together in the same tube of neutralization solution.
▶ Buffer PBI contains a pH indicator. The solution should promptly return to its neutral/acidic yellow color after the addition of each Melt Solution wash and mixing. If it does not, add an extra 5 μ l of the 3 M Sodium Acetate pH 5.2 solution to fully neutralize the melts.
- 7 Purify the neutralized DNA library using one column from a MinElute PCR Purification Kit (Qiagen). Follow the manufacturer's instructions for using spin columns and a microcentrifuge, with the following **exceptions**:
 - a. Do not use any additional PBI
 - b. Perform **two** PE washes to remove all residual salts from the sample
 - c. After the PE dry spin, rotate the column 180° and spin an additional **30 seconds** to ensure complete removal of the ethanol.
 - d. Elute with **15 μ l** of TE Buffer (from the GS FLX Titanium General Library Preparation Kit; room temperature).

3.10 DNA Library Quality Assessment and Quantitation

3.10.1 Library Quality Assessment and Physical Quantitation

- 1 Run a **1 µl** aliquot of the final (single-stranded) DNA library on a BioAnalyzer RNA Pico 6000 LabChip, to assess the quality of the library.
 - ▶ For representative traces of DNA libraries prepared from high molecular weight DNA (nebulized), see section 5.6; for libraries made from LMW DNA (non-nebulized), see section 5.7.
 -  ▶ To run RNA Pico 6000 LabChips, the BioAnalyzer must have software version 2.12 or later, and the mRNA Pico assay must be selected.
 - ▶ The RNA ladder must be prepared according to the manufacturer's guidelines, which include denaturation before use. For best stability, store the denatured stock at -80°C, in aliquots containing 1 day's supply.

- 2 Quantitate the DNA library (**1 µl**, in triplicate) by fluorometry. Use the RiboGreen method (Invitrogen), and follow the manufacturer's instructions.

- 3 Assess the quality of the DNA library for the characteristics listed in Table 3-1:

Library Characteristic	Expected Result	
	HMW DNA (Nebulized)	LMW DNA sample
Average fragment length	between 500 bp and 800 bp	between 150 bp and 800 bp
Lower size cut-off	<10% below 350 bp	N/A
Upper size cut-off	<10% above 1000 bp	---
DNA yield	≥ 5 ng	≥ 5 ng
Adaptor dimer peak	<5% of library peak height	<5% of library peak height

Table 3-1: Quality and quantity assessment of General DNA libraries

-  **Deviation from expected results:** If the library deviates from the results in Table 3-1 by a single large variation or multiple smaller variations, it may not be suitable for sequencing. Consider repeating the library preparation.

3.10.2 Library Primary Dilution and Storage

- 1 From the RiboGreen quantitation results above, expressed in ng/µl, calculate the library concentration equivalence in molecules/µl, using the following equation:

$$\text{Molecules}/\mu\text{l} = \frac{(\text{Sample conc.}; \text{ng}/\mu\text{l}) \times (6.022 \times 10^{23})}{(328.3 \times 10^9) \times (\text{avg. fragment length}; \text{nt})}$$

... where 6.022×10^{23} is Avogadro's number (molecules/mole); 328.3 is the average molecular weight of nucleotides, in g/mole; and avg. fragment length is the result from the DNA 7500 LabChip profile from section 3.3, plus 60 nt for the length of the Adaptors.

-  **Note:** The GC content of the library will impact the estimated size determined by the RNA Pico 6000 LabChip. High GC libraries will appear smaller while low GC will appear larger than their actual size. For the calculation above, use the DNA 7500 LabChip profile from section 3.3 for a more accurate estimation of the average fragment length of your library.

- 2 Dilute **2 µl** of the library to 1×10^8 molecules/µl, in TE Buffer.
- 3 Store the concentrated library and, if not used immediately for the determination of the amount needed for the emPCR amplification procedure, the 1×10^8 molecules/µl stock, at -15 to -25°C.

3.10.3 Determination of the Amount of Library to Use in emPCR Amplification

Clonality in the emPCR amplification reaction requires that a single effective DNA template molecule be carried on each bead. If the optimal amount of DNA is not added to each bead, the sequencing Run will not produce optimal results. Specifically:

- ▶ If too little DNA is added, emPCR amplification will produce a relatively large number of beads that do not carry any DNA; those beads will not produce a positive signal in a sequencing reaction, resulting in wasted wells.
- ▶ If too much DNA is added, some beads will contain multiple amplifiable templates; those beads will keypass but will result in unusable reads that will be filtered out by the Genome Sequencer System software quality filter as either “mixed” or “dot” reads. (See the *Genome Sequencer Data Analysis Software Manual* for more details on quality filters, and on keypass, mixed, and dot reads.)

The amount of a DNA library that will produce a “single effective DNA template molecule per bead” depends on DNA quality, composition, and other unidentified factors. Therefore, it is not sufficient to physically quantitate the DNA library, as done above. A separate determination of the optimal amount of library DNA to use as input to the emPCR amplification process is also essential.

This library preparation method offers two options for optimizing the amount of a DNA library to be used for emPCR amplification. Each user should select the option which best supports his or her circumstances and experimental requirements.

3.10.3.1 Option 1: Emulsion Titration Assay

The emulsion titration assay is a fairly quick and inexpensive test whose output, the % enriched beads in emPCR amplification reactions, can be used as a proxy for the expected sequencing results. During the emulsion titration, various amounts of library are added to a fixed number of DNA Capture Beads (from a GS FLX Titanium SV emPCR Kit (Lib-L)), and carried through the emPCR amplification procedure, including enrichment of the DNA-carrying beads and counting of those enriched beads. The proportion of final enriched beads to the total number of input beads can be used as an indicator for the quality of the amplified library: the optimal amount of DNA to use in emPCR amplification, for the best sequencing results, is typically the amount which yields approximately 8% Enriched Beads (a range of 6 - 10% Enriched Beads is usually acceptable).



The emulsion titration assay described below requires a GS FLX Titanium SV emPCR Kit (Lib-L) and a GS FLX Titanium emPCR Filters SV 64pcs Kit. Please see the *GS FLX Titanium emPCR Method Manual* for complete details.

The emulsion titration assay is done as follows:

- 1 Get the 1×10^8 molecules/ μl stock of the quantitated DNA library to be tested (if it is frozen, thaw it before use), and dilute **2 μl** into **198 μl** of TE Buffer to make a 1×10^6 molecules/ μl solution.
- 2 Set up four single-tube emPCR amplification reactions (2.4×10^6 Capture Beads per tube), and prepare samples containing four different amounts of DNA library, as follows:
 - a. Tube 1: 1.2 μl of diluted DNA library (= 0.5 molecule/bead)
 - b. Tube 2: 2.4 μl of diluted DNA library (= 1 molecule/bead)
 - c. Tube 3: 4.8 μl of diluted DNA library (= 2 molecules/bead)
 - d. Tube 4: 9.6 μl of diluted DNA library (= 4 molecules/bead)

3 Vortex the four tubes for 5 seconds to mix their contents.

- 4 Perform the rest of the emPCR amplification procedure, using the “Small Volume Emulsion” procedure described in the *GS FLX Titanium emPCR Method Manual*.
 - ▶ The enriched beads are counted at the end of the emPCR amplification procedure.

- 5 For each amount of DNA input, calculate the Enriched Beads as a percentage of the total number of beads used:

$$\% \text{ Enriched Beads} = \frac{\text{Number of final enriched beads}}{2.4 \times 10^6 \text{ total beads}} \times 100$$

- 6 For large scale sequencing on this library, use the amount of input DNA that gives an enriched bead yield of approximately 8%.
 - ▶ You may interpolate between the 4 data points. For example, if the results of the emulsion titration are:

0.5 molecule/bead = 1% Enriched Beads

1 molecule/bead = 3% Enriched Beads

2 molecules/bead = 6% Enriched Beads

4 molecules/bead = 12% Enriched Beads

then you could interpolate that 3 molecules/bead would yield approximately 8% Enriched Beads.

- ▶ If all four amounts of DNA tested in the emulsion titration assay yield a % Enrichment Beads below (or, more rarely, above) 8%, you may have incorrectly assessed the physical concentration of the library. If this happens, either repeat the RiboGreen fluorometric assay and perform the titration with the corrected results, or simply repeat the emulsion titration with more or less input DNA (e.g. 4, 8, 16 and 32 molecules/bead; this may require a new dilution of the stock library, e.g. to 4×10^6 molecules/ μl).

- ▶ If a poor correlation is observed between the amount of input DNA and the % Enriched beads, the emulsion titration can be done with duplicate tubes rather than single tubes, at each amount of DNA.

3.10.3.2 Option 2: Full Sequencing Titration Assay

In less frequent cases, such as when a large number of sequencing Runs will be carried out on a library (e.g. a large genome to be sequenced at high depth of coverage), the time, effort and cost of a formal functional optimization of the library amplification may be warranted: in such as case, any increased sequencing yield brought by such optimization would be multiplied by the number of Runs. Additional circumstances when this may be useful are for new users who have yet to characterize the system's performance in their laboratory, or for users handling libraries of very rare or otherwise precious DNA.

The sequencing titration assay is a more extensive and complete option to determine the amount of a DNA library to use for amplification by emPCR amplification. It consists in a set of emPCR amplification reactions carried out with various amounts of input DNA, as in the emulsion titration assay, above, followed by a sequencing Run to determine functionally the amount of input DNA that generates the best sequencing results. The highest yield and sequencing quality are obtained when the largest number of beads carry a single amplified template. This can be recognized as the library amount that yields the highest percentage of reads that passed all the quality filters. The GS Run Browser application offers a convenient interface to view these results. (See the *Genome Sequencer Data Analysis Software Manual* for more details on the GS Run Browser application.)



The sequencing titration assay described below comprises both emPCR amplification and sequencing reactions. It requires a GS FLX Titanium SV emPCR Kit (Lib-L), a GS FLX Titanium emPCR Filters SV 64pcs Kit, a GS FLX Titanium Sequencing Kit XLR70, a GS FLX Titanium PicoTiterPlate Kit 70 × 75 (using the small regions “multi-lane” gasket), and a Genome Sequencer FLX Instrument. Please see the *GS FLX Titanium emPCR Method Manual* and the *GS FLX Titanium Sequencing Method Manual* for complete details.

The sequencing titration assay is done as follows:

- 1 Carry out the emulsion titration assay described in section 3.10.3.1.
- 2 Load up to 125,000 beads from each of the 4 amplified library aliquots on a PicoTiterPlate device, using a small regions (2 × 53 mm) “multi-lane” gasket.
 - ▶ The lower DNA input reactions (e.g. 0.5 molecules/bead) may not yield that number of enriched beads. In such a case, load all the beads produced by this reaction. The assay will show a correspondingly low number of reads, which is the correct assessment for a small DNA input.
 - ▶ Make sure to add 1 µl of Control DNA Beads to each sample, as described in the *GS FLX Titanium Sequencing Method Manual*.
- 3 Carry out the entire sequencing procedure on the Genome Sequencer FLX Instrument. Find the number of totalPassedFiltering reads (for the Library key), using the GS Run Browser or in the 454QualityFilterMetrics.csv (or .txt) file generated by the GS Run Processor application (see the *Genome Sequencer Data Analysis Software Manual* for details on the GS Run Browser and GS Run Processor software).
- 4 For large scale sequencing on this library, use the amount of input DNA that gives the largest number of totalPassedFiltering reads. A good library should give at least 25,000 totalPassedFiltering reads in the best region.



Two of the main factors influencing the optimal DNA input amount for emPCR amplification are the quality (or type) of DNA sample and variation between users. Therefore, user experience, especially with a certain sample type (e.g. bacterial genomic DNA from standardized culture conditions, DNA from standardized human blood samples, etc.) can sometimes help determine an approximate DNA input to use. For many common purposes, an input of 1.5 or 2 molecules of library DNA per emPCR bead will generate satisfactory sequencing results.

Using a pre-determined, fixed amount of DNA input offers the experienced user the obvious advantage of a faster process: no additional steps would be required following the Library Quality Assessment and Physical Quantitation (section 3.10.1) and the Library Primary Dilution (section 3.10.2), and the library would be ready for use directly in emPCR amplification with the expectation of reasonably good sequencing results. Even if the resulting sequencing Run is not optimal, a significant amount of data will be obtained, without the expense of any optimization. In addition, these results can be used not only as a full data Run towards reaching the goal of the experiment but also, if the experiment calls for further sequencing Runs with this library, to further optimize the amount of DNA input in the emPCR amplification of the DNA material for these further Runs. However, users should note that all system specifications have been determined with duly titrated libraries.

3.10.4 Preparation of Working Aliquots

- 1 When the amount of library to use for the emPCR amplification reaction has been determined, return to the 1×10^8 molecules/ μl stock prepared in section 3.10.2, above, and allow it to thaw.
- 2 Prepare enough of the appropriate working dilution for the number of amplification reactions/sequencing Runs you anticipate doing with this library.
 -  An appropriate dilution is often around 2×10^6 molecules/ μl . To determine the size and number of aliquots to prepare, bear in mind that:
 - ▶ the amount of library to pipet for emPCR amplification must be no less than 1 μl ; and not more than 100 μl for Large Volume emulsions or 10 μl for Small Volume emulsions
 - ▶ each Large Volume emulsion contains 35×10^6 beads, and each Small Volume emulsion, 2.4×10^6 beads
 - ▶ multiple parallel emulsion reactions can be made from a single aliquot of a DNA library, but the aliquots are single-use: leftovers of a diluted library aliquot should not be refrozen.

See the *GS FLX Titanium emPCR Method Manual* for more details.

- 3 Distribute this working stock into aliquots (e.g. 100 μl if you will be doing Large Volume emulsions; 25 μl if you will be doing Small Volume emulsions), and store them at -15 to -25°C. (Re-freeze the leftover 1×10^8 molecules/ μl stock as well.)



It is recommended to carry out an emulsion titration on an aliquot of the working dilution library preparation to ascertain that the working aliquots were diluted accurately.

An alternative to this re-assay would be to prepare the working aliquots upfront and do the titration assay (section 3.10.3) on one of these aliquots. Of course, this would require advanced knowledge of the concentration needed, in effect of the result of the titration, but experienced users can often make a good approximation of this (see the Note at the end of section 3.10.3).

4. Where to Go from Here

When these procedures are completed, the sample is ready for the amplification phase of the Genome Sequencer System. In practice, this means that the initial DNA sample has been:

- ▶ processed into a library of single-stranded DNA fragments, each flanked with a 5'–Adaptor A and a 3'–Adaptor B,
- ▶ stored in quantitated aliquots at a concentration appropriate for emPCR amplification.
- ▶ and the amount of this library needed for optimal results in the emulsion-based clonal amplification (emPCR) procedure has been determined.

In the next phase of the experiment, you will use the GS FLX Titanium LV emPCR Kit (Lib-L) or GS FLX Titanium SV emPCR Kit (Lib-L) to clonally amplify the library, in preparation for the sequencing Run. This is described in detail in the *GS FLX Titanium emPCR Method Manual*.

5. Appendix

5.1 Table of Materials Required but Not Provided

Some pieces of equipment or standard laboratory supplies, as well as some third-party reagents used in this procedure, are not provided but are required to carry out the General DNA Library preparation described in this manual. These items are listed in Table 5–1. Make sure that all necessary items are available prior to beginning an experiment.



The specific items identified by Source and Ref. Number in Table 5–1 are examples (available in North America) that have been demonstrated to work well in the procedure, though alternatives may also perform adequately. Please contact your Roche Representative for any questions regarding these items or possible substitutions.

Equipment	Quantity Required	Source	Ref. Number
Ventilation System (hood vented to exterior)*	1	Labconco	4862010 (plus accessories)
Thermal Cycler (incubation chamber)	1	Many possible	N/A
96 well, 0.2 ml block for Thermal Cycler	1	Many possible	N/A
BioAnalyzer	1	Agilent	2100
Compressed Nitrogen – Research Grade 5.0*	1	Many possible	N/A
Dual-stage regulator*	1	TechAir	2123351-000
1/4" (6.35 mm) hose barb fitting with 1/4" (6.35 mm) NPT female threads*	1	Many possible	N/A
Flexible tubing (1/4" (6.35 mm) ID), with stainless steel screw clamp**	Length from N2 tank to Nebulizer	Many possible	N/A
Fluorometer	1	Many possible	N/A
Heating Dry-block (optional)	1	Many possible	N/A
Microcentrifuge (1000–16000 RCF)	1	Eppendorf	5415D
Magnetic Particle Concentrator	1	Invitrogen	123-21D
LabQuake Rotator	1	Thermolyne	400110/400220
Agarose Gel Apparatus (15 × 15 cm) and power supply	1	Many possible	N/A
Ultraviolet light box	1	Many possible	N/A

Lab Supplies/Consumables	Quantity Required	Source	Ref. Number
RNA 6000 Pico LabChip	1	Agilent	5067-1513
DNA 7500 LabChip	1	Agilent	5067-1506
DNA 1000 LabChip*	1	Agilent	5067-1504
MinElute PCR Purification Kit	5 columns	QIAGEN	28004
AMPure 60 ml Kit AMPure 5 ml Kit ^a	per lot calibration ^b	Agencourt	000130 A50850
RiboGreen RNA Quantitation Kit	1 assay	Invitrogen	R-11490
NaOH (10 N)	125 µl	Many possible	N/A
1.7 ml microcentrifuge tubes	6	Dot Scientific	RA-1700-GMT
0.2 ml Tubes with caps	14	Dot Scientific	620-PCR
Full set of micropipettes, 2–1000 µl	1 ea.	Rainin	RL series
Pipette Tips	1 box ea.	Rainin	RT-LxF series
GTG SeaKem Agarose ^c	1.5 g	Lonza	50071
TAE Buffer ^c	2 l	Many possible	N/A
Ethidium Bromide (0.005%)	10 µl	Many possible	N/A
Gel Loading Dye	2 µl	Many possible	N/A
DNA Molecular Weight Maker XIV	10 µl	Roche	11 721 933 001
QIAquick Gel Extraction Kit (50)	1 column	QIAGEN	28704
Rubber Stopper	1	Fisher Scientific	14-135b
Millipore Filter ^d	1	Roche	05 233 674 001
3M Sodium Acetate Buffer pH 5.2	10 µl	Sigma	S-7899

Table 5–1: Materials required but not supplied with the GS FLX Titanium General Library Preparation Kit

Items identified under “Source” (and corresponding Ref. Numbers) are examples only. ^a Each Nebulizer comes with approximately 2 m (7 ft) of tubing; additional tubing is needed only if the nitrogen source is further away than this. ^b Each lot of AMPure beads must be calibrated for use in this procedure; the amount needed will depend on this calibration (section 5.3) and on the choice of fragment size selection method (Gel Cut, section 3.2.1; or Double SPRI, section 3.2.2). ^c Used only when the Gel Cut option for fragment size selection is chosen. ^d The Millipore filter used to cap the Nebulizers is the same item as the filters included in the GS FLX Titanium emPCR Filters SV 64pcs Kit. *These items are not used in the Low Molecular Weight DNA Application.

In addition, the last step of the General library preparation is the determination of the proper amount of library DNA to use as input to emPCR amplification reactions (section 3.10.3). This is critical for the optimal efficiency of the emPCR amplification process. Two options are available to make this determination:

- 1) an emulsion titration procedure, and
- 2) a sequencing titration conducting a series of mini amplification and sequencing experiments using various amounts of the library.

Depending on the option chosen, you will need the following (in addition to the GS FLX Titanium General Library Preparation Kit):

- ▶ For option 1:
 - ▶ GS FLX Titanium SV emPCR Kit (Lib-L) (4 reactions)
 - ▶ GS FLX Titanium emPCR Filters SV 64pcs (4 filters)
- ▶ For option 2:
 - ▶ GS FLX Titanium SV emPCR Kit (Lib-L) (4 reactions)
 - ▶ GS FLX Titanium emPCR Filters SV 64pcs (4 filters)
 - ▶ GS FLX Titanium Sequencing Kit XLR70
 - ▶ GS FLX Titanium PicoTiterPlate Kit 70 × 75 (using a gasket with small regions, included)
- ▶ All the materials listed in the *GS FLX Titanium emPCR Method Manual* and/or the *GS FLX Titanium Sequencing Method Manual*, as appropriate.

For details on:

- ▶ the two titration options, see section 3.10.3 of this manual;
- ▶ the emPCR amplification procedure, see the *GS FLX Titanium emPCR Method Manual*;
- ▶ the sequencing reaction and the operation of the Genome Sequencer FLX Instrument, see the *GS FLX Titanium Sequencing Method Manual* and the *Genome Sequencer FLX Operator's Manual*.

5.2 Reagents Prepared by the User

5.2.1 Melt Solution



Hazardous Chemicals – Sodium Hydroxide Solution (10 N): Sodium hydroxide is a highly corrosive chemical that may cause burns if it contacts eyes or skin. Reaction with water is exothermic. When working with 10 N solutions of sodium hydroxide, always follow standard safety procedures to minimize the potential hazards, as described in the MSDS.

Ingredient	10 ml Preparation
NaOH (10 N)	0.125 ml
Molecular Biology Grade Water	9.875 ml

- 1 Combine the ingredients listed and mix thoroughly.
- 2 Store at ambient temperature (+15 to +25°C).
 **Shelf life:** Melt Solution has a shelf life of 7 days; indicate the expiration date on the container, and do not use after the expiration date has passed.

5.3 AMPure Bead Calibration Procedure



AMPure bead calibration: Due to significant variability in the size exclusion characteristics between individual lots of AMPure beads, a calibration of each lot is necessary before these beads can be used for the preparation of DNA libraries in the GS FLX Titanium Sequencing system. Make sure to always use AMPure beads from a lot calibrated per the procedure provided in this section for the preparation of your DNA libraries. This calibration procedure will determine the specific amounts of AMPure beads to use from the lot calibrated, for libraries prepared using each of the two size selection methods: Gel Cut (section 3.6) and Double SPRI (sections 3.2.2 and 3.6).

In the DNA library preparation procedure described in this manual, AMPure beads are used to remove low molecular weight DNA fragments from the library. During library preparation, the beads are added directly to the DNA sample and mixed, allowing the larger DNA fragments to adhere to the beads. Once the appropriately sized DNA fragments adhere to the magnetic AMPure beads, a Magnetic Particle Concentrator (MPC) is used to pull these beads to the wall of the tube, and subsequent wash steps are performed to remove the unbound low molecular weight DNA fragments.

The actual size cut-off of AMPure beads is extremely concentration dependent, and varies from lot to lot, such that the beads:sample (vol:vol) ratio must be controlled with great care: if the bead:sample ratio is too low, only very large fragments will be retained, creating a library that is too long; if, on the other hand, the bead:sample ratio is too high, undersize fragments will bind to the AMPure beads, creating a library that is overall too short.

To ensure consistency of the results obtained with various lots of AMPure beads, a calibration assay procedure is used to determine the size exclusion characteristics of any given AMPure bead lot. This calibration will determine the ratio of AMPure beads to DNA sample (by volume) to use during library preparation with either the Gel Cut or the Double SPRI size selection methods, to create the optimal size library for sequencing in the Genome Sequencer System using the GS FLX Titanium chemistry.

In this calibration assay, a 100 bp DNA ladder is incubated with AMPure beads in beads:DNA ratios ranging from 0.5:1 to 1:1 (vol:vol). Each bead:DNA ratio will provide different fragment size cut-off parameters. These cut-offs are assessed by running the DNA retained by the beads in each condition on an Agilent BioAnalyzer DNA 7500 Lab-Chip, and recording the DNA concentration in the 200-500 bp range (normalized to the 900 bp peak, which should be stable in the range of bead:DNA ratios of the assay). The optimal bead:DNA ratio to use for Gel Cut and Double SPRI DNA libraries with the bead lot being tested is determined by comparing the results of this calibration assay with the empirically-derived optimal data provided below.

! Critical pipetting accuracy: While this protocol calls for the usual standards of good laboratory practice, be especially careful when pipetting the viscous bead suspension to ensure that the exact amounts intended for deposit in each tube are accurately delivered. In particular:

- ▶ pipetting the viscous bead suspension too quickly may result in a poorly acquired volume;
- ▶ dipping the pipette tip too deep and withdrawing it too fast from the viscous bead suspension may result in a droplet hanging on the outside surface of the tip, which would risk being improperly delivered;
- ▶ dispensing the viscous bead suspension too quickly may result in some of the slurry remaining in the tip and not being delivered.

See the photographs below for illustrations of good and poor pipetting. If any of these circumstances occurs, dispense the amount drawn back into the original tube of beads, and pipette again using a fresh tip.

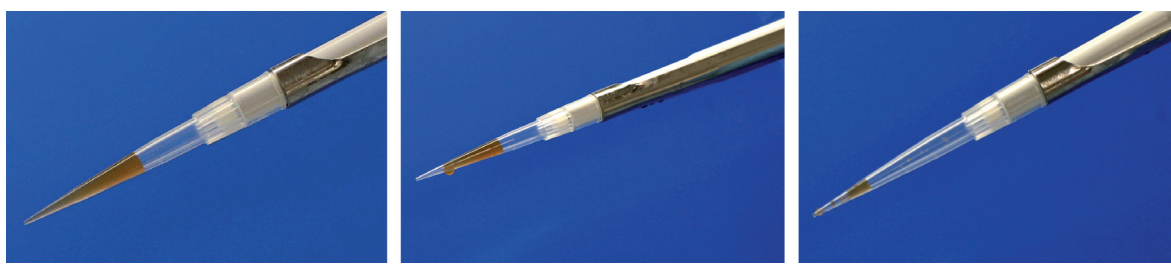

Pipetted correctly

Pipetted and withdrawn too quickly



Delivered too quickly

5.3.1 Materials Needed:

Equipment/Supplies	Quantity Required	Source	Ref. Number
AMPure 60 mL Kit	900 μ l	Agencourt	000130
AMPure 5 mL Kit			A50850
1.7 ml microcentrifuge tubes	24	Dot Scientific	RA-1700-GMT
Full set of micropipettes, 2-1000 μ l	1 ea.	Rainin	RL series
Pipette Tips	1 box ea.	Rainin	RT-LxF series
DNA Molecular Weight Maker XIV	52 μ l	Roche	11 721 933 001
Molecular Biology Grade Water	1158 μ l	Fisher Scientific (Eppendorf)	E0032006205
Magnetic Particle Concentrator	1	Invitrogen	123-21D
Ethanol 70%	11 ml	Many possible	N/A
Heating Dry-block (optional)	1	Many possible	N/A
Tris-HCl, 10 mM, pH8.0	110 μ l	Many possible	N/A
BioAnalyzer	1	Agilent	2100
DNA 7500 LabChip	1	Agilent	5067-1506

Table 5 2: Materials needed for the AMPure Beads calibration assay

5.3.2 Procedure

- 1 Label eleven 1.7 ml tubes for the eleven bead:DNA ratios to be included in the assay, from 0.50 : 1 to 1.00 : 1, in increments of 0.05, per the table, below.
- 2 In a fresh microcentrifuge tube place **48 µl** of the 100 bp DNA ladder, and dilute it with **1152 µl** of Molecular Grade Water
- 3 Aliquot **precisely 100 µl** of diluted DNA ladder to each labeled microcentrifuge tube, per the table, below.
 -  There will be 100 µl of diluted ladder remaining, that can be discarded.
- 4 Vortex the tube of AMPure beads vigorously and aliquot **900 µl** into a fresh microcentrifuge tube. You will use this aliquot for the rest of the procedure.
- 5 Using the same pipettor as used to measure the 100 µl aliquots of diluted DNA ladder, **add the appropriate amount of beads** to each sample, per the table below. Make sure to:
 - a. vortex the bead aliquot between each sample;
 - b. change tips between each sample;
 - c. pipette the beads slowly, making sure that you do not aspirate any air, and that there are no beads on the outside of the tip;
 - d. dispense slowly such that ALL the beads are delivered into the sample.
 -  **Pipetting Accuracy:** Be as exact as possible in your pipetting. Accuracy is critical to the successful calibration of the AMPure bead lot.

Beads:DNA ratio (by volume)	Diluted DNA Ladder (µl)	AMPure Beads (µl)
0.50 : 1	100	50
0.55 : 1	100	55
0.60 : 1	100	60
0.65 : 1	100	65
0.70 : 1	100	70
0.75 : 1	100	75
0.80 : 1	100	80
0.85 : 1	100	85
0.90 : 1	100	90
0.95 : 1	100	95
1.00 : 1	100	100

Table 5-3: Volumes of Diluted DNA ladder and of AMPure beads for each Beads:DNA ratio of the assay

- 6 Vortex all the tubes, and incubate them at room temperature for **5 minutes**.
- 7 Using the Magnetic Particle Concentrator (MPC), pellet the beads against the wall of the tube. This may take several minutes due to the high viscosity of the suspension.
- 8 Remove the supernatant and wash the beads **twice** with **500 µl** of 70% Ethanol, incubating for 30 sec each time.
 - ▶ Larger DNA fragments will bind to the AMPure beads, with a decreasing size cut-off as the Bead:DNA ratio increases; the DNA fragments from the DNA ladder that are below the cut-off in each of the incubation conditions will thus be washed away in the next step.



-
- 9 Remove all the supernatant from each tube and allow the AMPure beads to air dry completely.
 - ▶ The drying time can vary due to environmental conditions and the amount of residual fluid left in the tubes.
 - ▶ The tubes may be placed in a heating block set to 37°C (with their caps open) to reduce drying time; visible cracks forming in the pellets are an indication that the beads are dry.

 - 10 Remove the tubes from the MPC, add **10 µl** of 10 mM Tris-HCl, pH 8.0 (or Qiagen's Buffer EB) to each tube, and vortex them to resuspend the beads.
 - ▶ This step elutes the size-selected DNA ladder from the AMPure beads.

 - 11 Using the MPC, pellet the beads against the wall of the tube once more, and transfer the **supernatants** containing the **size-selected DNA ladder** to a set of fresh, appropriately labeled microcentrifuge tubes.

 - 12 Separately, dilute **4 µl** of fresh DNA ladder with **6 µl** of Molecular Biology Grade Water
 - ▶ This aliquot of unprocessed, diluted DNA ladder will serve as a control.

 - 13 Run **1 µl** of each size-selected DNA ladder, including the control ladder, on a single BioAnalyzer DNA 7500 LabChip.

5.3.3 Analysis



Before starting, set the BioAnalyzer "Height Threshold" to 5, on the assay properties tab in the expert 2100 software.

Results will show the gradual removal of small fragments from the DNA ladder samples, as the Beads:DNA ratio decreases (i.e. only large fragments bind to the beads at low bead ratio). To assess this, the DNA concentration of the 200 to 500 bp peaks is monitored in the 12 LabChip traces (11 tests samples and the non-selected control ladder). The peak at 900 bp should be retained in the whole range of bead:DNA ratios tested, and is used for normalization between the traces.

-
- 1 For each of the 12 traces, divide the DNA concentration (in ng/µl) of each of the following 4 peaks, by the DNA concentration of the 900 bp peak for that trace:
 - a. 200 bp
 - b. 300 bp
 - c. 400 bp
 - d. 500 bp

 - 2 Compare the sets of 4 values for each of the 11 size-selected DNA ladders, with the values for columns 2 and 3 of Table 5.4.
 - ▶ **For Gel Cut libraries:** in section 3.6, use the ratio of AMPure beads:DNA (by volume) that generated the set of peak concentration values most similar to the values given in column 2. If the target falls between two values choose the ratio that produces the higher value.
 - ▶ **For Double SPRI libraries:** in sections 3.2.2 and 3.6, use the ratio of AMPure beads:DNA (by volume) that generated the set of peak concentration values most similar to the values given in column 3. If the target falls between two values choose the ratio that produces the higher value.
 - ▶ Make sure to also verify that the peak ratios in the control trace are similar to the values given in column 4. If they don't, load a new LabChip and re-run the analysis.

Peak ratio (DNA concentrations)	Optimal Values for Gel Cut Libraries	Optimal Values for Double SPRI Libraries	Values for the Control DNA Ladder
200/900	0.3	N/A	0.7
300/900	0.9	0.4	1.1
400/900	1.3	0.7	1.4
500/900	3.4	2.9	3.4

Table 5-4: Optimum ratios of the DNA concentration in the low molecular weight peaks to the 900 bp peak

The trace that generated the set of 4 values most similar to the values given in column 2 corresponds to the AMPure Bead:DNA ratio to use when preparing a DNA library using the Gel Cut size selection method (section 3.6).

The trace that generated the set of 3 values most similar to the values given in column 3 corresponds to the AMPure Bead:DNA ratio to use when preparing a DNA library using the Double SPRI size selection method (sections 3.2.2 and 3.6).



Note that the AMPure removal of small fragments is more stringent for Double SPRI libraries (column 3) than for Gel Cut libraries (column 2). This is necessary because AMPure purification of the nebulized library fragments leaves a fairly broad distribution (see Figure 5-5B, below); using these stringent conditions twice per the Double SPRI method (in sections 3.2.2 and again in section 3.6), results in the adequate removal of the small library fragments. With the Gel Cut size selection method, by contrast, the sides of the fragment size distribution are quite steep (see Figure 5-5A, below), so most of the small library fragments have already been removed by excising the gel slice (in section 3.2.1) and the purpose of the AMPure bead purification in section 3.6 is just to remove Adaptor and Adaptor dimers, all very small molecular species.

The three figures below show typical traces produced by the non-selected control DNA ladder (Figure 5–1), and by the optimal Bead:DNA ratios for use with Gel Cut (Figure 5–2) and Double SPRI DNA libraries (Figure 5–3).

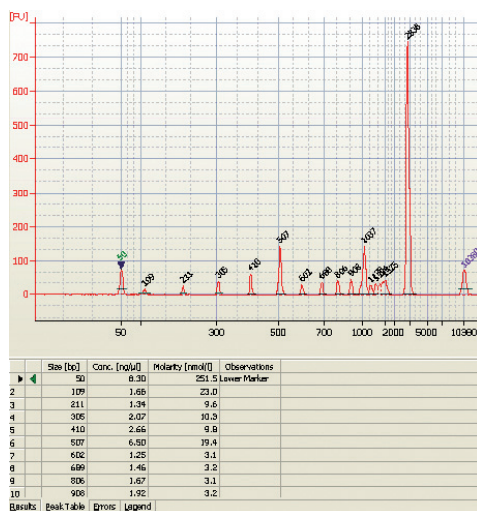

Figure 5–1: Example DNA 7500 LabChip trace of a non-selected control ladder

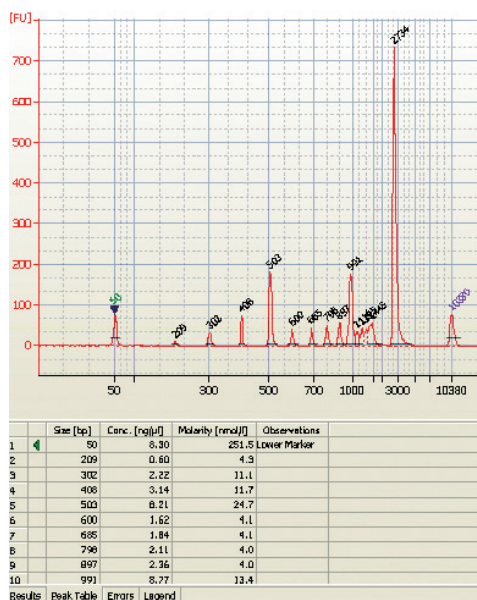

Figure 5–2: Example DNA 7500 LabChip trace of a DNA ladder selected with the beads: DNA ratio optimal for processing Gel Cut DNA libraries

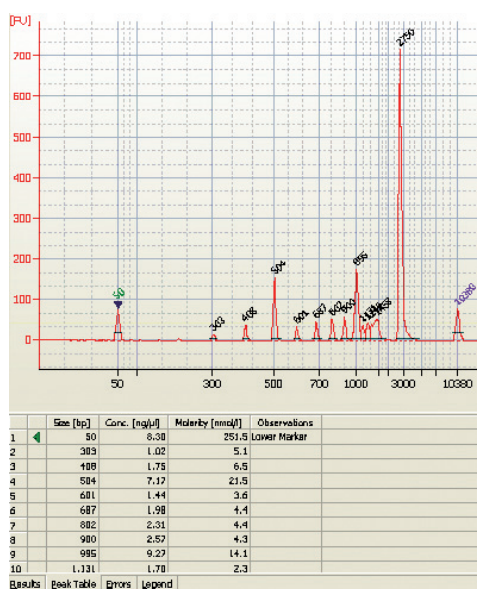

Figure 5–3: Example DNA 7500 LabChip trace of a DNA ladder selected with the beads: DNA ratio optimal for processing Double SPRI DNA libraries

5.4 Gel-Cut Example

Figure 5-4 shows a photograph of an agarose gel processed per the Gel-Cut size selection method. The sample was loaded between two lanes of the 100 bp ladder (the 500 and 1000 bp marker bands are darker than the others). In the sample lane, the region encompassing fragments in the 500 to 800 bp range has been excised for further processing. The bright streak below the cut out represents small fragments resulting from nebulization which, if they were not removed from the DNA library, would interfere with proper sequencing.

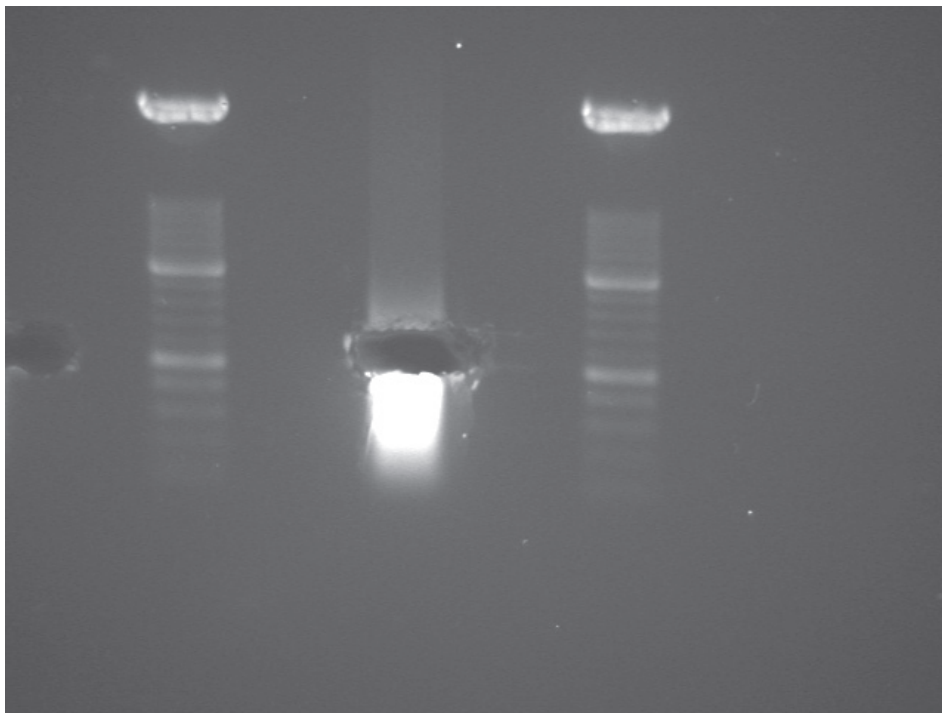

Figure 5-4: Agarose gel after excising the 500-800 bp slice, per the Gel-Cut size selection method
The gel depicted on this photograph was run with the DNA Molecular Weight Marker XIV (100-1500 bp) from Roche Diagnostics.

5.5 Example of an Agilent 2100 Trace of a Nebulized and Size-Selected DNA Sample

Figure 5–5A shows a typical Agilent 2100 DNA 7500 LabChip profile for 1 μ l of the DNA material after nebulization and size selection (Gel Cut method; section 3.3), for high molecular weight DNA. The mean size (top of peak) is between 500 and 800 bp, and no more than ~10% of the material is below 350 bp or above 1000 bp. Figure 5–5B shows the profile of a good sample size-selected using the Double SPRI method; the peak is characteristically somewhat broader than with the Gel Cut method. Figure 5–5C, finally, shows the profile of a poor sample (Gel Cut method); note the broadening of the peak to the left.

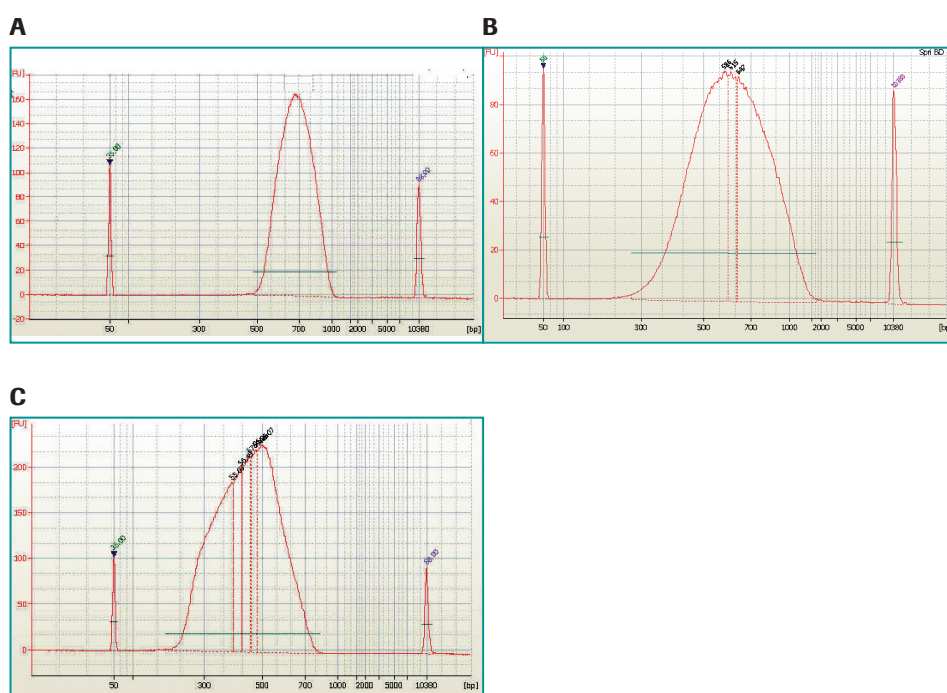

Figure 5–5: Agilent 2100 traces of nebulized and size-selected DNA samples

- (A) The DNA 7500 LabChip profile of a good nebulized DNA sample, size-selected by the Gel Cut method. The two sharp peaks are internal markers at 50 and 10,380 bp.
- (B) The DNA 7500 LabChip profile of a good nebulized DNA sample, size-selected by the Double SPRI method.
- (C) The DNA 7500 LabChip profile of a poor sample. Note the broadening of the peak to the left; more than 10% of the sample DNA peak is below 350 bp.

5.6 Example of an Agilent 2100 Trace of a Final Library

Figure 5–6A shows a typical Agilent 2100 RNA Pico 6000 LabChip profile for 1 μ l of the final DNA library material from a complex, high molecular weight DNA sample, prepared using the Gel Cut size selection method (section 3.10.1, above). The top of the peak is between 500 and 800 nt; no more than 10% of the DNA library is smaller than 350 nt or larger than 1000 nt; and only a very minimal dimer peak is visible, at approximately 60 bp. Figure 5–6B shows a similar trace, for a sample processed using the Double SPRI size selection method. Figure 5–6C, finally, shows the trace of a poor sample, exhibiting a large dimer peak.

Acceptable sequencing results can be obtained as long as the dimer peak is less than approximately 5% of the height of the library peak. Adaptor dimers may be removed by an additional purification over a MinElute PCR Purification Kit (Qiagen); however, if the yield of the library is low (< 500 pg/ μ l), it is best to repeat the library preparation using more DNA.

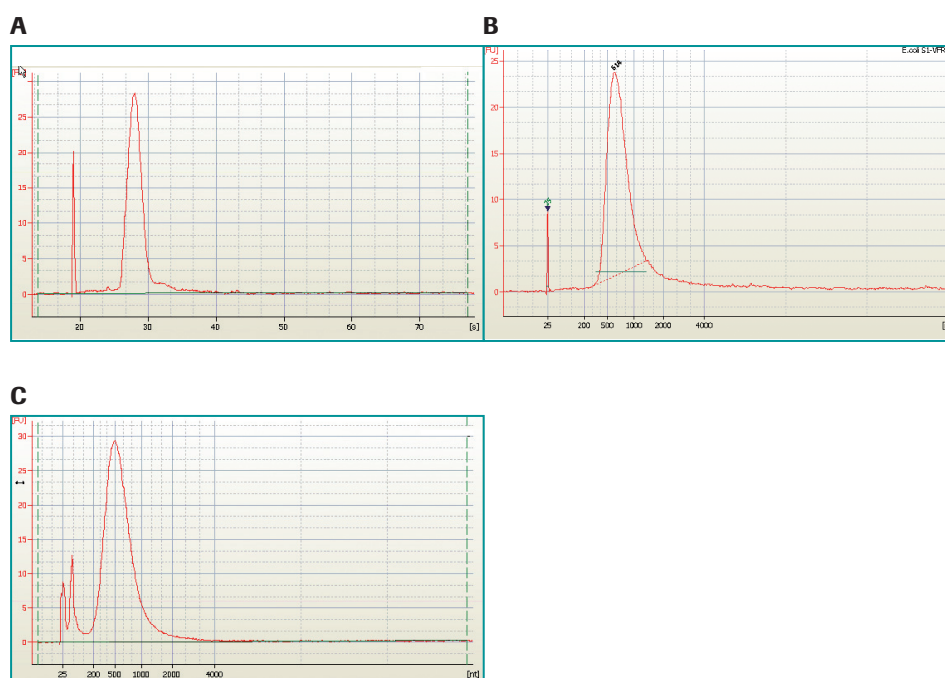

Figure 5–6: Agilent 2100 traces of final high molecular weight DNA libraries

- (A) The RNA Pico 6000 LabChip profile of a good DNA library, prepared from a complex, high molecular weight DNA sample and size-selected using the Gel Cut method. The sharp peak at 25 nt is an internal marker.
- (B) The RNA Pico 6000 LabChip profile of a good DNA library, prepared from a complex, high molecular weight DNA sample and size-selected using the Double SPRI method.
- (C) The RNA Pico 6000 LabChip profile of a poor sample. Note the substantial dimer peak around 60 nt, with a height well above 5% of the library peak height.

5.7 Example BioAnalyzer Traces for LMW DNA Samples and Prepared Libraries

Figure 5–7A shows the Agilent 2100 BioAnalyzer DNA 1000 LabChip profile for 1 μ l of a low molecular weight DNA sample comprising multiple discrete fragment sizes. The mean size (top of peak) should reflect the expected size of the sample DNA. The peaks at 15 and 1500 bp are internal markers.

Figure 5–7B shows the RNA Pico 6000 LabChip profile for 1 μ l of the final DNA library prepared from the material in Figure 5–7A. The mean size of the DNA library should be approximately equal to the starting size plus 60 bases. Note that the appearance of the single peak in Figure 5–7B does not reflect the multiple peaks seen in the starting material; this is typical since the RNA chip has a lower resolution when used to analyze single-stranded DNA.

Also, an Adaptor or Adaptor dimer peak may be visible at approximately 60 bp. Adaptor dimers may be removed by an additional purification over a MinElute PCR Purification Kit (Qiagen); however, if the yield of the library is low (*e.g.* <500 pg/ μ l), or if the expected size of the library is small, it may be more advantageous to repeat the library preparation.

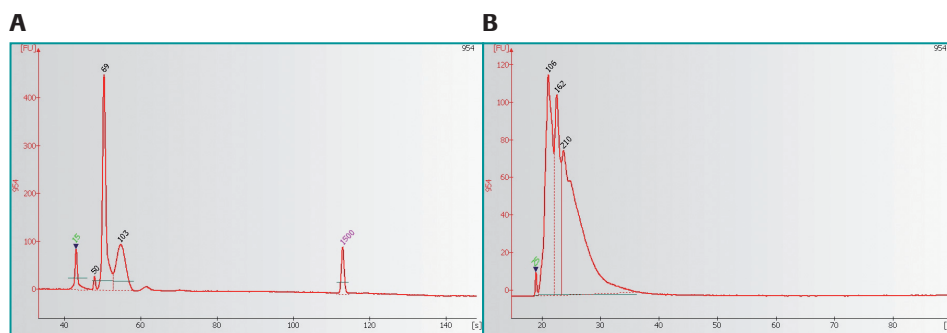

Figure 5–7: Agilent 2100 BioAnalyzer profiles for a low molecular weight DNA sample comprising multiple discrete fragment sizes

(A) DNA 1000 LabChip profile for a good sample of the input DNA

(B) RNA Pico 6000 LabChip profile of a good DNA library prepared from such a sample, using the procedure described in this manual

Figure 5–8, Figure 5–9, and Figure 5–10 show representative profiles for DNA libraries derived from a single amplicon, a cDNA sample, and a DNA preparation made from microRNA, respectively. These examples are provided as a guide and for reference only. Individual samples may vary considerably from the profiles shown and still be successfully sequenced. The quality and purity of the input DNA are the main determinants of whether a good quality library can be made.

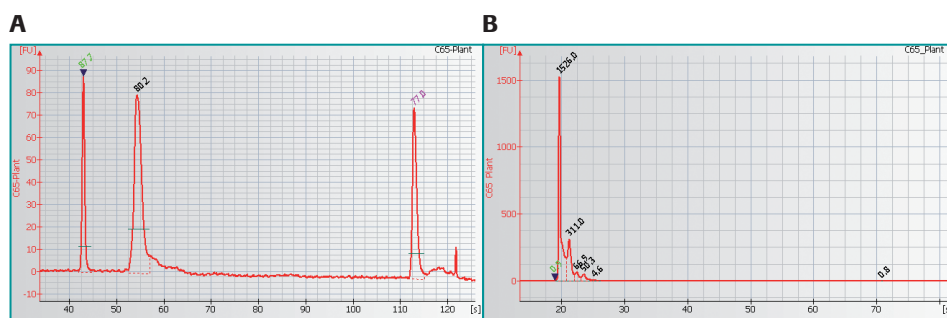

Figure 5–8: Agilent 2100 BioAnalyzer profiles for a sample comprising a single DNA amplicon

(A) DNA 1000 LabChip profile of the input DNA sample

(B) RNA Pico 6000 LabChip profile of a DNA library prepared from such a sample

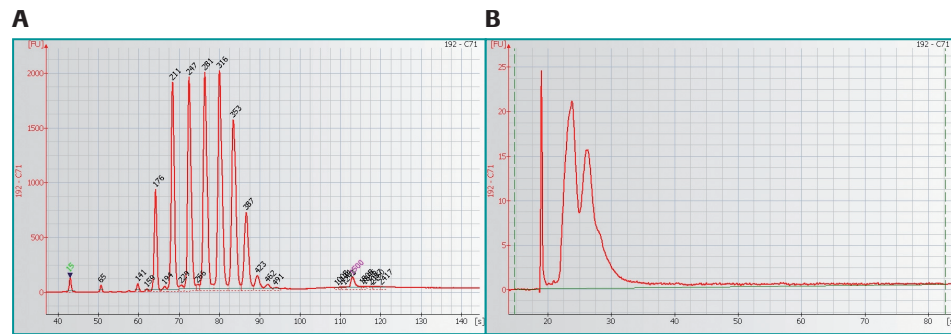

Figure 5-9: Agilent 2100 BioAnalyzer profiles for a multiplex cloned cDNA sample
(A) DNA 1000 LabChip profile of the input DNA sample
(B) RNA Pico 6000 LabChip profile of a DNA library prepared from such a sample

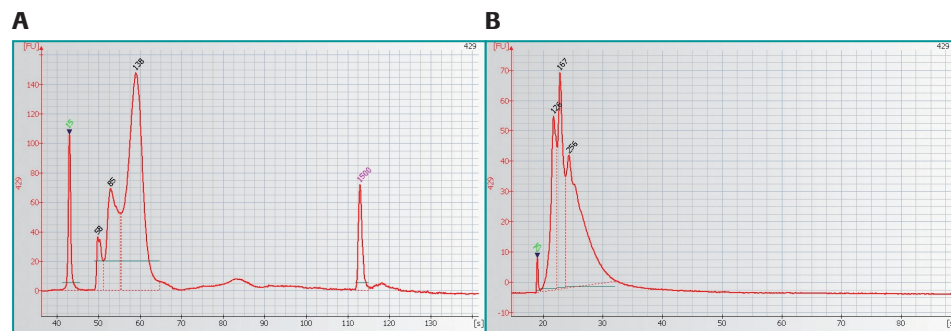

Figure 5-10: Agilent 2100 BioAnalyzer profiles for a DNA sample made from a microRNA preparation
(A) DNA 1000 LabChip profile of the input DNA sample
(B) RNA Pico 6000 LabChip profile of a DNA library prepared from such a sample

5.8 Additional Information

5.8.1 Revision History

Manual Version	Instrument Version	Software Version	Revision Date
FLX.01 – USM-00012.J	GS FLX	1.1.01	December 2006
FLX.02 – USM-00012.K	GS FLX	1.1.02	June 2007
FLX.03 – USM-00030.A	GS FLX	1.1.03	December 2007
FLX.Ti.00 – USM-00048.A	GS FLX	2.0.00	October 2008
FLX-Ti.00 – USM-00048.B	GS FLX	2.0.01	April 2009

Every effort has been made to ensure that all the information contained in this document was correct at the time of printing. However, 454 Life Sciences Corporation and Roche Diagnostics GmbH reserve the right to make corrections, clarifications, updates, or any other changes deemed necessary, for any reason, without advance notice.

No part of this document may be reproduced or transmitted in any form or by any means, electronic or mechanical, for any purpose, without express written permission. Questions or comments regarding the contents of this manual can be directed to the address below or to your Roche Representative or to the customer support address below:

454 Life Sciences Corporation
1 Commercial St.
Branford, CT
USA 06405

5.8.2 Related Publications

A full suite of publications are available that describe in detail the components and usage of the Genome Sequencer System:

- ▶ *Genome Sequencer FLX Operator’s Manual (April 2009)*
- ▶ *Genome Sequencer FLX Titanium Methods Manual, including:*
 - ▶ *GS FLX Titanium General Library Preparation Method Manual – this manual*
 - ▶ *GS FLX Titanium 20 kb and 8 kb Span Paired End Library Preparation Method Manual*
 - ▶ *GS FLX Titanium 3 kb Span Paired End Library Preparation Method Manual*
 - ▶ *GS FLX Titanium emPCR Method Manual*
 - ▶ *GS FLX Titanium Sequencing Method Manual*
 - ▶ A Quick Guide version of each method is also included.
- ▶ *Genome Sequencer Data Analysis Software Manual*
- ▶ *Genome Sequencer System Site Preparation Guide (April 2009)*
- ▶ *GS LIMS Implementation Guide (December 2007)*

Note also that some of the applications of the Genome Sequencer FLX standard System (December 2007) are not yet available for the GS FLX Titanium chemistry. These include the preparation and usage of Amplicon libraries, and of Multiplex Identifiers (MIDs). For these applications, the Genome Sequencer FLX standard System methods and kits must still be used. The December 2007 GS FLX manual set comprises the following:

- ▶ *Genome Sequencer FLX Operator's Manual (December 2007)*
- ▶ *Genome Sequencer FLX System Methods Manual*, including:
 - ▶ *GS FLX Shotgun DNA Library Preparation Method Manual (superseded except MIDs)*
 - ▶ *GS FLX Paired End DNA Library Preparation Method Manual (superseded)*
 - ▶ *GS FLX Amplicon DNA Library Preparation Method Manual*
 - ▶ *GS FLX emPCR Method Manual*
 - ▶ *GS FLX Sequencing Method Manual*
 - ▶ A Quick Guide version of each Method is also included.
- ▶ *Genome Sequencer FLX Data Analysis Software Manual (December 2007)*
- ▶ *Genome Sequencer System Site Preparation Guide (December 2007)*

All Genome Sequencer Manuals, Guides and Bulletins are available three ways: in hardcopy form, on a CD from your Roche representative, or downloaded from the customer restricted access area of www.genome-sequencing.com.

5.8.3 Intended Use

The Genome Sequencer System is intended for life science research applications and must be used exclusively by laboratory professionals trained in laboratory techniques and having studied the instructions for use of its various associated kits.

5.8.4 Notice to Purchaser

RESTRICTION ON USE: Purchaser is only authorized to use the Genome Sequencer Instrument with PicoTiterPlate devices supplied by 454 Life Sciences Corporation and in conformity with the operating procedures contained in the Genome Sequencer System manuals and guides.

Made in USA by 454 Life Sciences Corporation, Branford, CT, USA, a Roche company.

For life science research only. Not for use in diagnostic procedures.

5.8.5 Trademarks

454, 454 LIFE SCIENCES, 454 SEQUENCING, GS FLX TITANIUM, emPCR, PICOTITERPLATE, and PTP are trademarks of Roche.

Other brands or product names are trademarks of their respective holders.

5.8.6 Assistance

If you have questions or experience problems with the Genome Sequencer System, please call, write, fax, or e-mail us.



When calling for assistance, be prepared to provide the serial number of your Genome Sequencer Instrument and/or lot number of the kit(s) you are using. The instrument's serial number is located on the label found on the back of the instrument cart.

If you are located in...	Please contact Roche Applied Science Technical Support via:	
USA or Canada	phone: 1-800-262-4911 (toll-free)	e-mail: us.gssupport@roche.com
Europe, Middle East, Asia Pacific, Mexico, South America or Africa	phone: +49-8856-60-6457 or toll-free +800SEQUENCE	e-mail: service.sequencing@roche.com
Japan	phone: +03-5443-5287	e-mail: tokyo.biochemicals@roche.com

Published by

Roche Diagnostics GmbH
Roche Applied Science
68298 Mannheim
Germany

© 2009 Roche Diagnostics
All rights reserved.

©0409